



AUDI A-4 sed. QUATRO

11/2000 -  
06/2001 -

AUDI A-4 Avant QUATRO

Cat. No. A/011

e20

e20\*94/20\*0377\*00

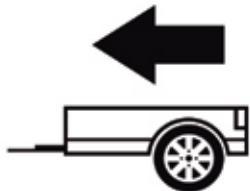

2000Kg



80Kg

**D** = 10,71kN

**D (kN) =**  $\frac{\text{MAX kg} \times \text{MAX kg}}{\text{MAX kg} + \text{MAX kg}} \times 0,00981$



MAX kg

x

MAX kg

x 0,00981



MAX kg

+

MAX kg



**IMIOLA HAK-POL**

96-111 KOWIESY, CHOJNATA 23 A, POLAND

tel. +48 46 831 73 31, fax +48 831 74 29

e-mail: office@imiola.pl, www.imiola.pl

## PRZEKRÓJ A-A

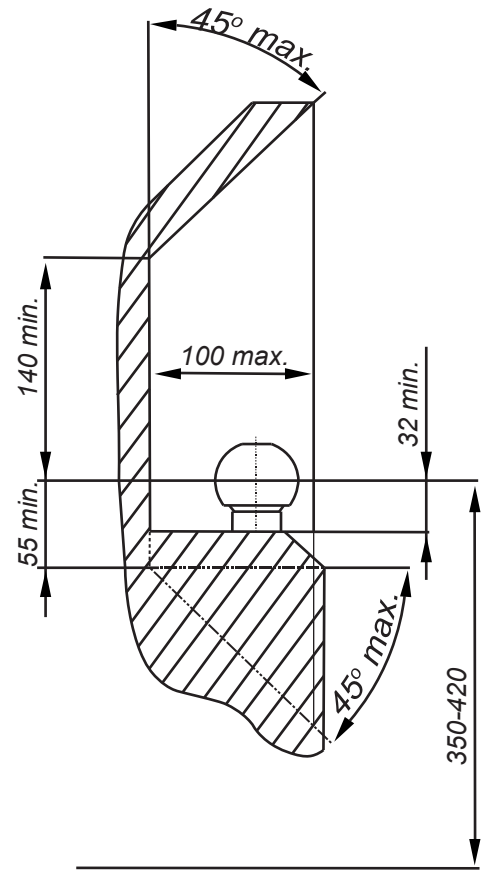
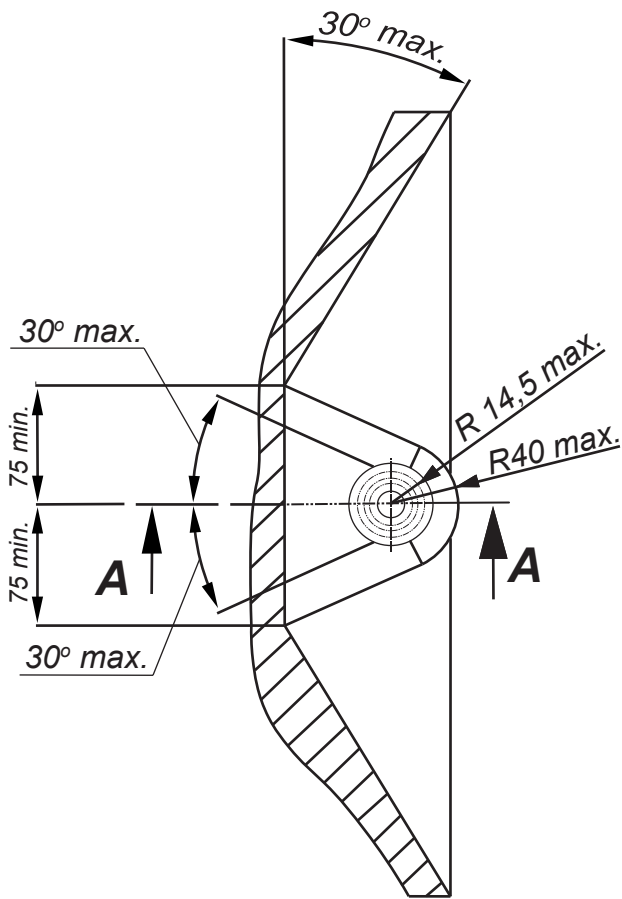

**PL** Należy zagwarantować przestrzeń swobodną według załącznika VII, rysunek 25a/b Regulaminu EKG ONZ 55.01 przy dopuszczalnym ciężarze całkowitym pojazdu.

**F** L'espace libre doit être garanti conformément à l'annexe VII, illustration de la réglementation 55.01 CE pour un poids total en charge autorisé du véhicule.

**GB** The clearance specified in appendix VII, diagram 25a/b of Regulation No. 55.01 UN EU must be guaranteed at laden weight of the vehicle.

**D** Der Freiraum nach Anhang VII, Abbildung 25a/b der Vorschriften 55.01 EG ist zu gew 25a/bahrleiten bei zulässigem Gesamtgewicht des Fahrzeuges.

Moment skręcający dla śrub i nakrętek (8.8) Torque settings for nuts and bolts (8.8)	
M8	25Nm
M10	55Nm
M12	85Nm
M14	135Nm
M16	195Nm

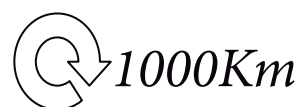

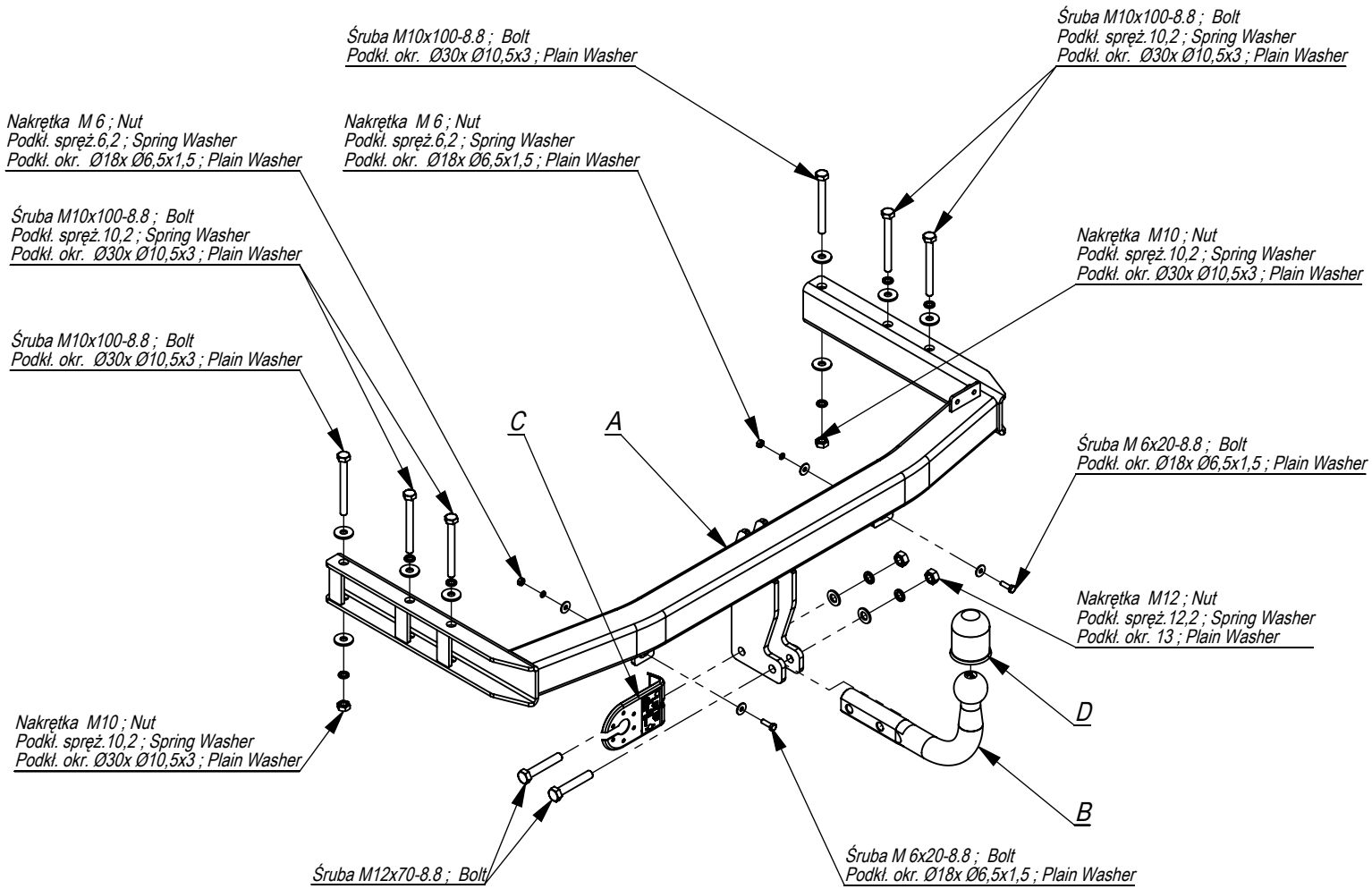

	A	x1		M12x70	2
				M10x100	6
				M6x20	2
	B	x1		M12	2
				M10	2
				M6	2
	C	x1		Ø30xØ10,5x3	8
				Ø18xØ6,5x1,5	4
	D	x1		13	2
				12,2	2
				10,2	6
				6,1	2

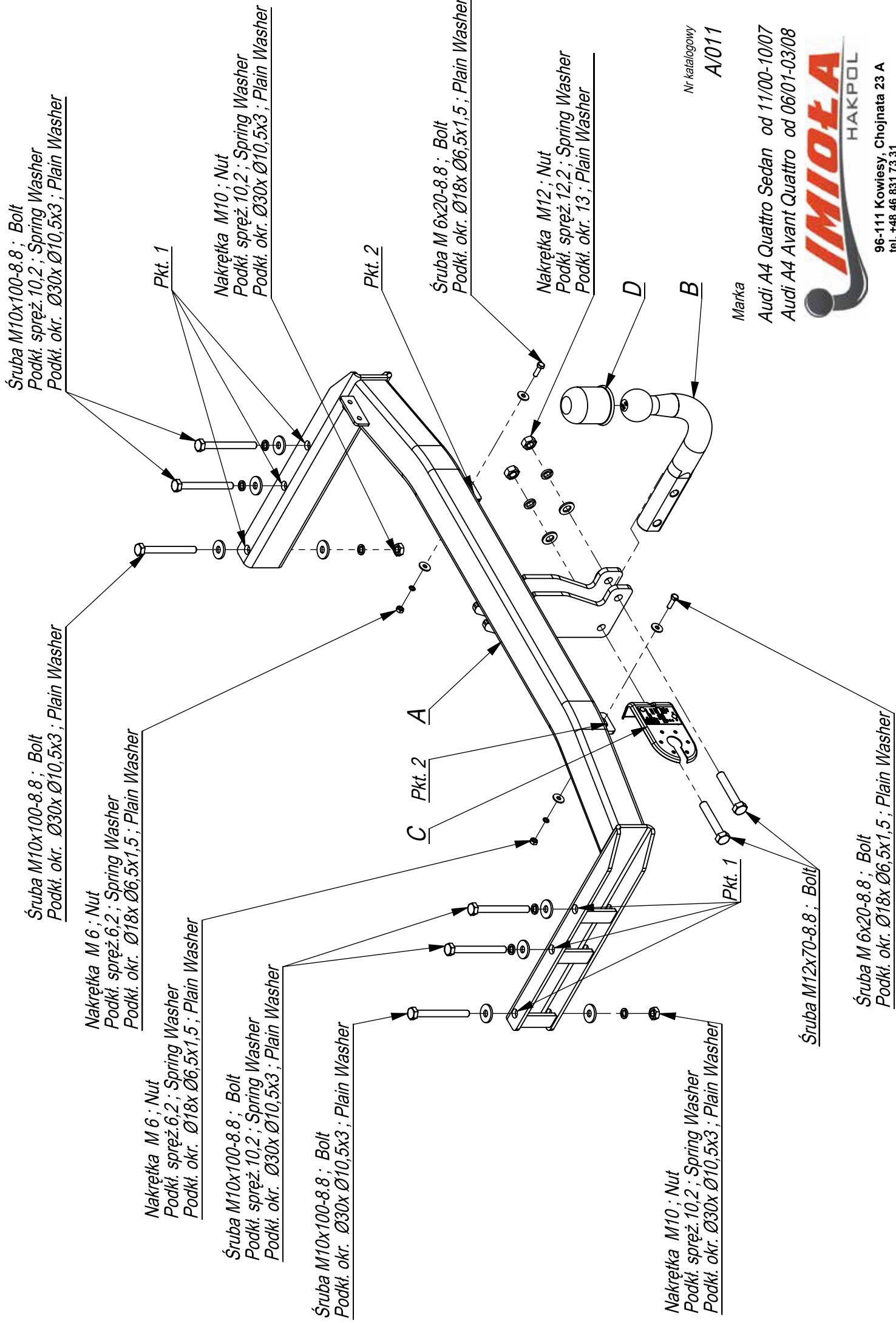

Nr katalogowy  
A/011

Marka

Audi A4 Quattro Sedan od 11/00-10/07  
Audi A4 Avant Quattro od 06/01-03/08



96-111 Kowiesy, Chojnata 23 A  
tel. +48 46 831 73 31



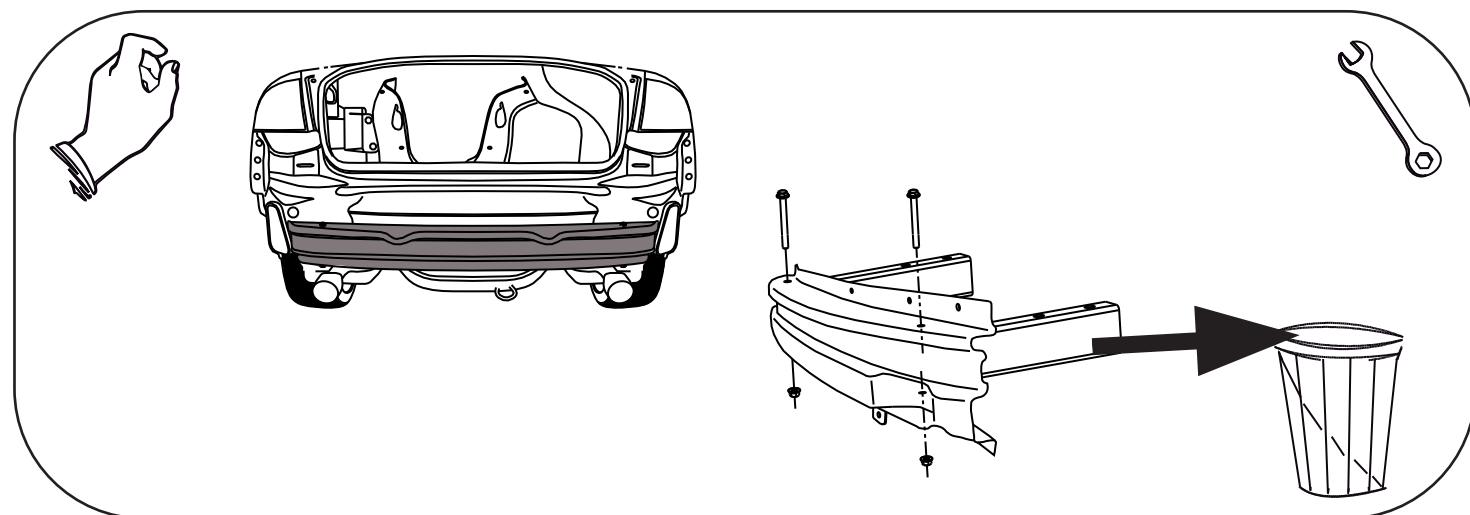
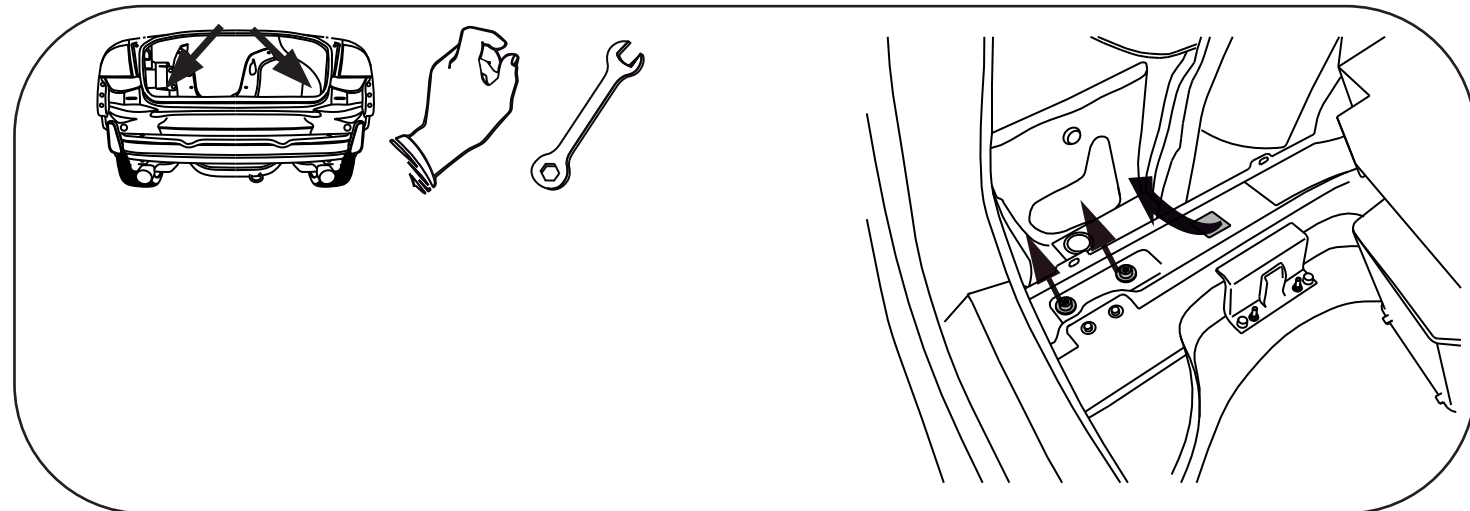
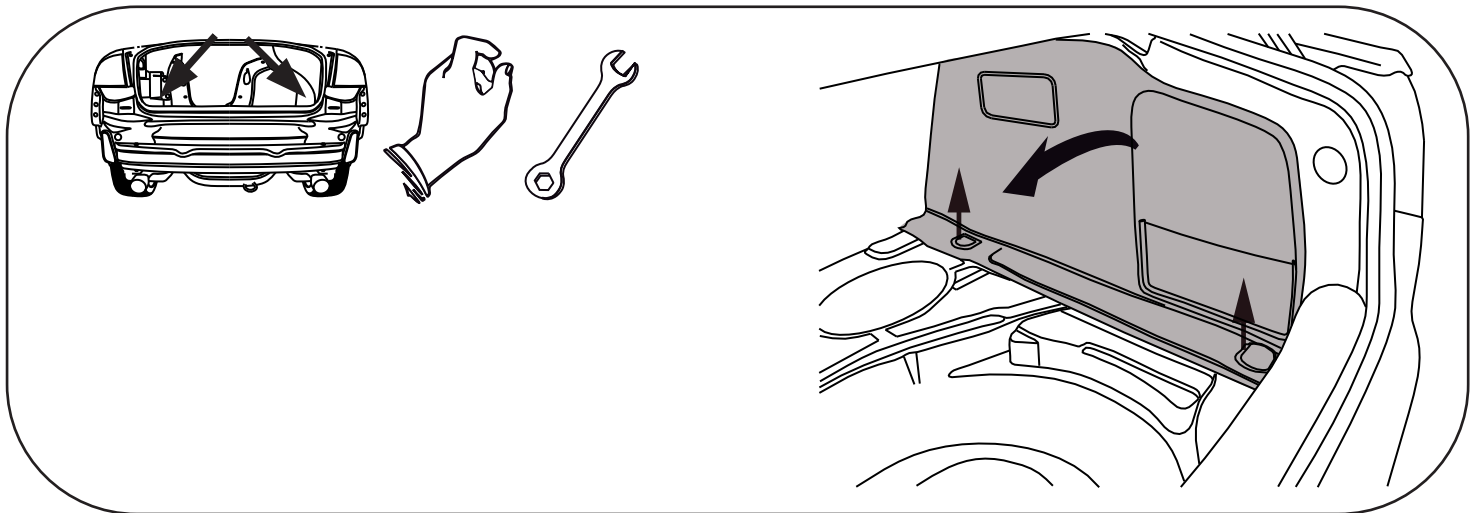
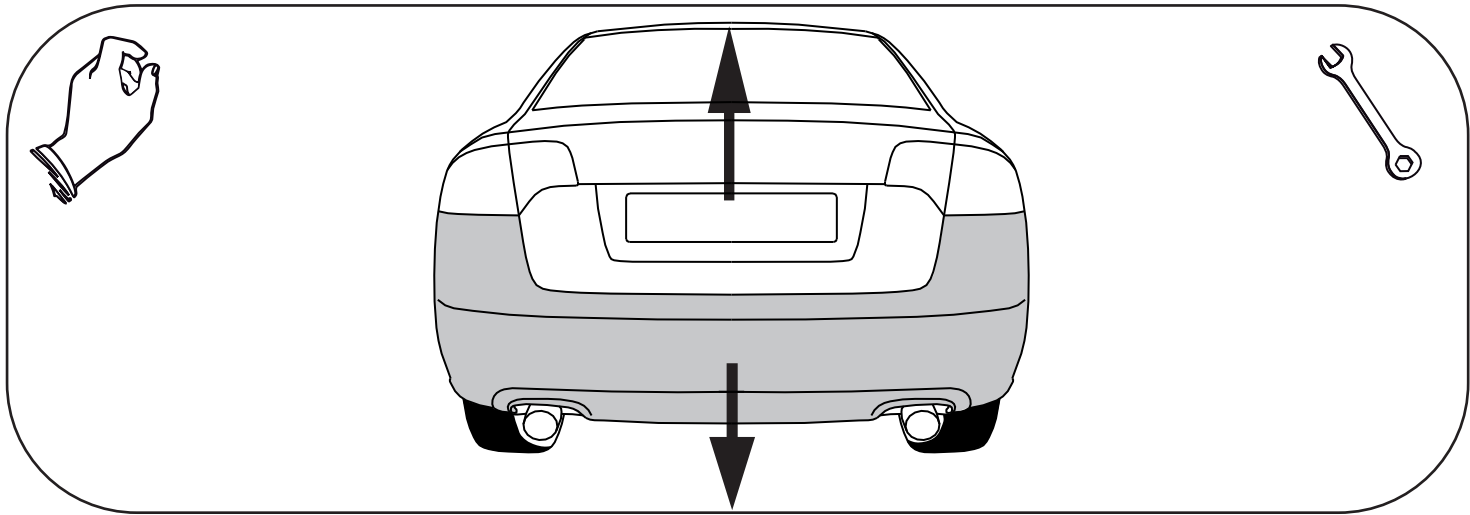

- Odkręcić zderzak.
- Odkręcić belkę zderzeniową (nie będzie już wykorzystana).
- Od wzmocnienia odnitować plastikowe uchwyty, przykręcić je do belki haka A śrubami M6x20 8.8 (pkt 2).
- Wsunąć hak do podłużnic i skręcić śrubami M10x100 8.8 (pkt 1).
- Wykonać wycięcie w dolnej części zderzaka 50x40.
- Wszystkie śruby dokręcić z momentem wg tabeli.
- Przykręcić zderzak.
- Przykręcić kulę i blachę gniazda elektrycznego.
- Podłączyć instalację elektryczną.

- Unscrew the bumper.
- Unscrew the bumper bar (it will not be used any more).
- Unrivet the plastic handles from the reinforcement, screw them to the main bar A with bolts M6x20 8.8 (point 2).
- Insert the tow bar in the metal clamps and screw with bolts M10x100 8.8 (point 1).
- Cut out the fragment measuring 50x40 in the lower part of the bumper.
- Tighten all the bolts according to the torque setting- see the table.
- Assemble the bumper.
- Fix the ball and electric plate.
- Connect the electric wires.

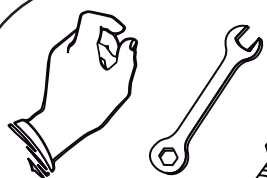



- Serrer le pare-chocs,
- Dévisser du longerons les fixations de pare-chocs (elles ne seront plus utilisées).
- Visser le pare-chocs au crochet (point 1 et 2) par les boulons M8x35 8.8.
- Insérer les bords de crochet D aux longerons, Visser le crochet par les boulons M10x100 8.8 à travers les ouvertures de longerons en utilisant les couvre-joints C
- Visser le crochet d'attelage et socle de prise électrique,
- Raccorder le circuit électrique.
- Serrer tous les boulons avec un couple de serrage selon tableau,



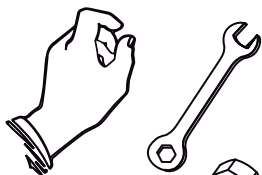
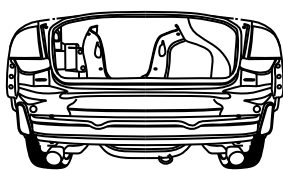
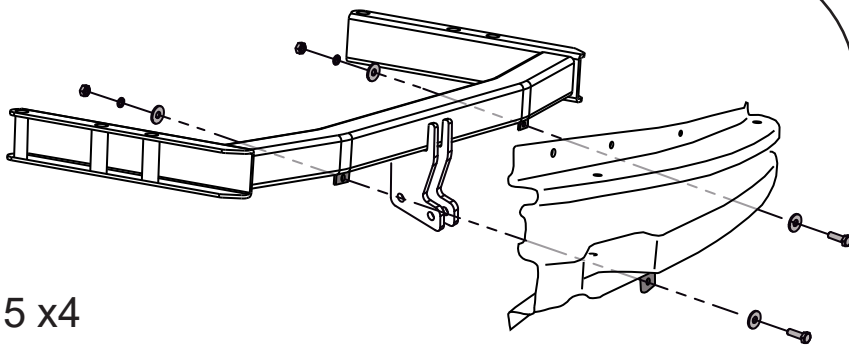





-  M6x20 x2
-  6,2 x2
-  Ø18xØ6,5x1,5 x4
-  M6 x2

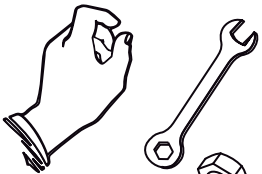
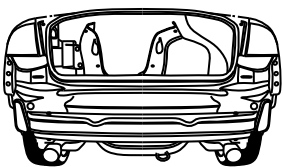
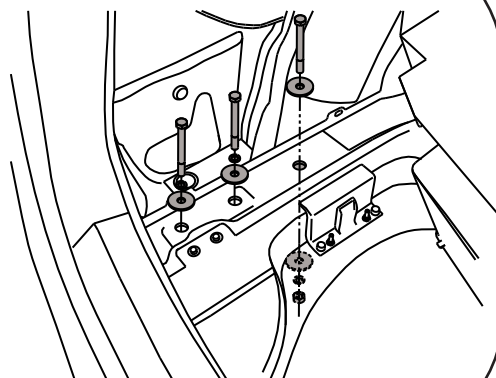

-  M10x100 x3
-  10,2 x3
-  Ø30xØ10,5x3 x4
-  M10 x1



-  M10x100 x3
-  10,2 x3
-  Ø30xØ10,5x3 x4
-  M10 x1

