



BMW SERIA X1

2009 -

Cat. No. **B/016**

e20

e20*94/20*****00

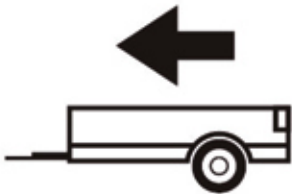

2000Kg



85Kg

D = 10,85kN

D (kN) =



MAX kg

x

MAX kg

x 0,00981



MAX kg

+

MAX kg



IMIOLA HAK-POL

96-111 KOWIESY, CHOJNATA 23A, POLAND

tel. +48 46 831 73 31, fax +48 831 74 29

e-mail: office@imiola.pl, www.imiola.pl

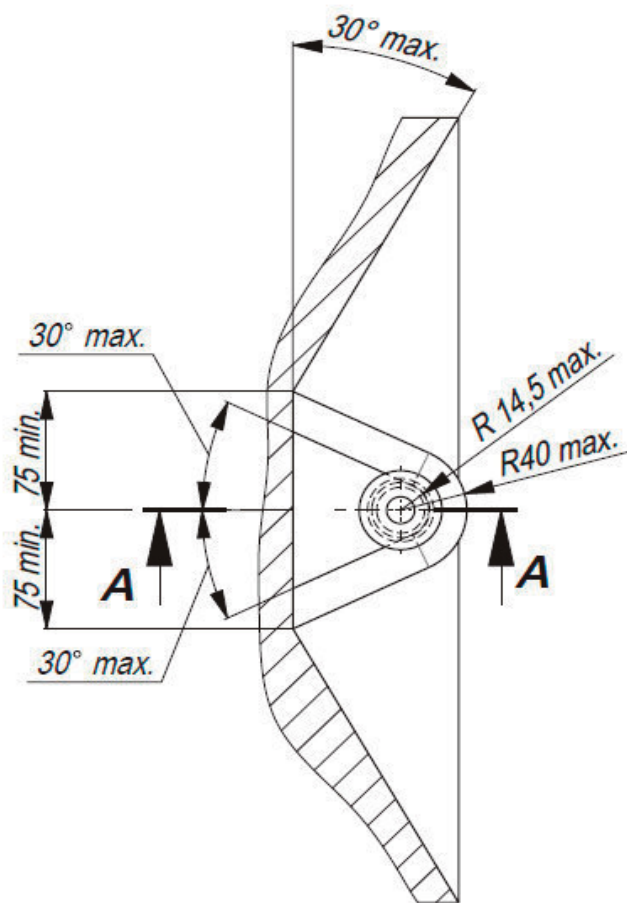

PRZEKRÓJ A-A

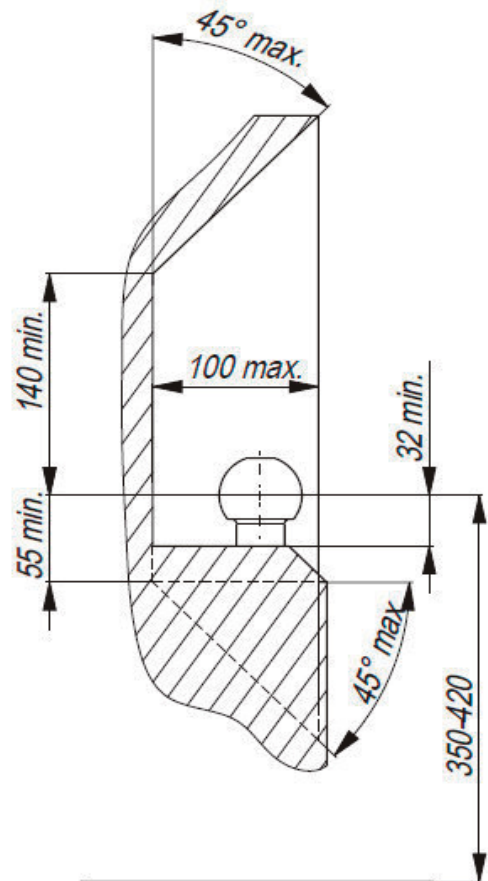

PL Należy zagwarantować przestrzeń swobodną według załącznika VII, rysunek 25a/b Regulaminu EKG ONZ 55.01 przy dopuszczalnym ciężarze całkowitym pojazdu.

GB The clearance specified in appendix VII, diagram 25a/b of Regulation No. 55.01 UN EU must be guaranteed at laden weight of the vehicle.

F L'espace libre doit être garanti conformément à l'annexe VII, illustration de la réglementation 55.01 CE pour un poids total en charge autorisé du véhicule.

D Der Freiraum nach Anhang VII, Abbildung 25a/b der Vorschriften 55.01 EG ist zu gew 25a/b abzuwehren bei zulässigem Gesamtgewicht des Fahrzeuges

Moment skręcający dla śrub i nakrętek (8.8)
Torque settings for nuts and bolts (8.8)

M8	25Nm
M10	55Nm
M12	85Nm
M14	135Nm
M16	195Nm



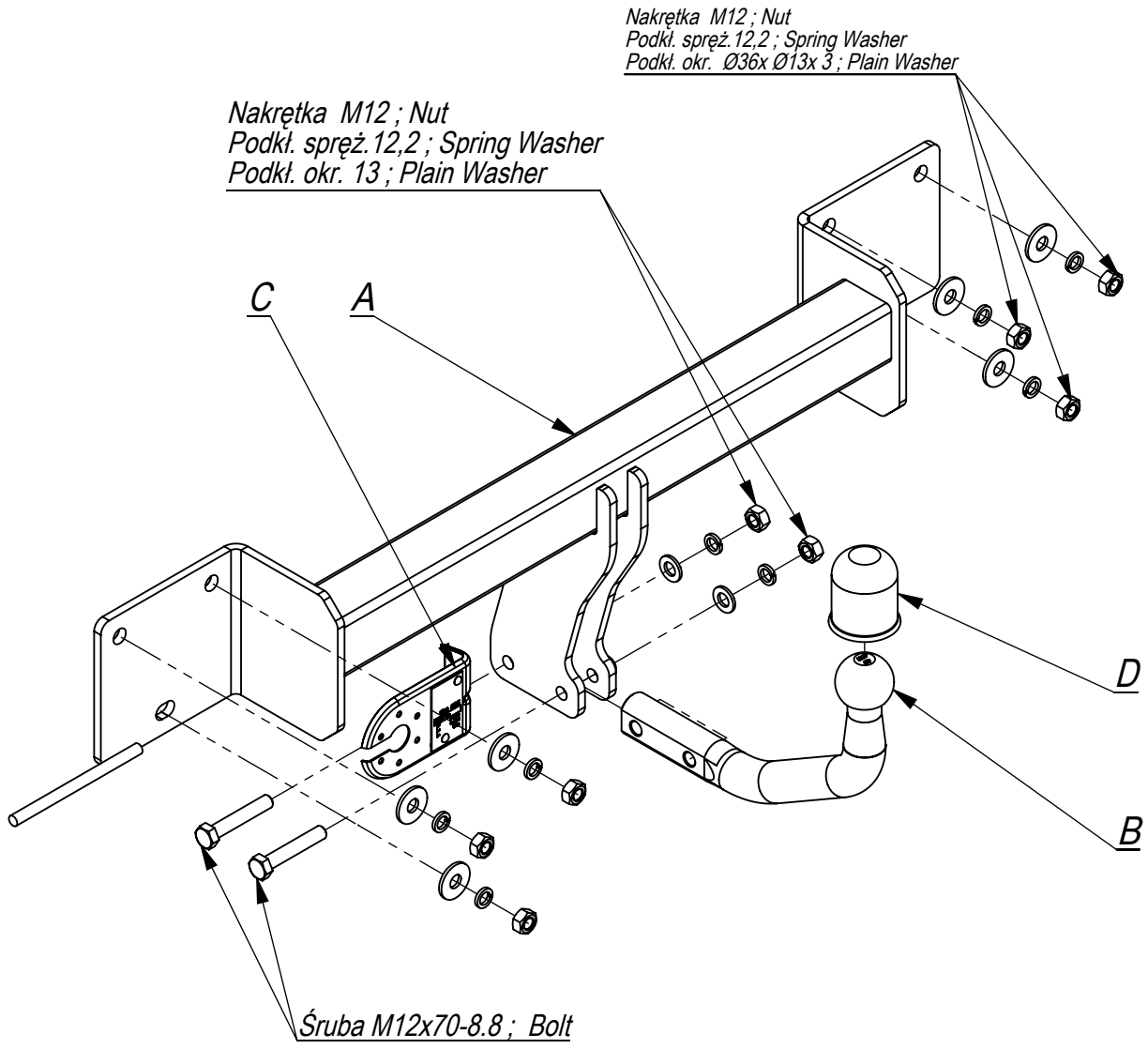

	A	x1		M12x70	2
	B	x1		M12	8
	C	x1		Ø36xØ13x3	6
	D	x1		13	2
				12,2	8

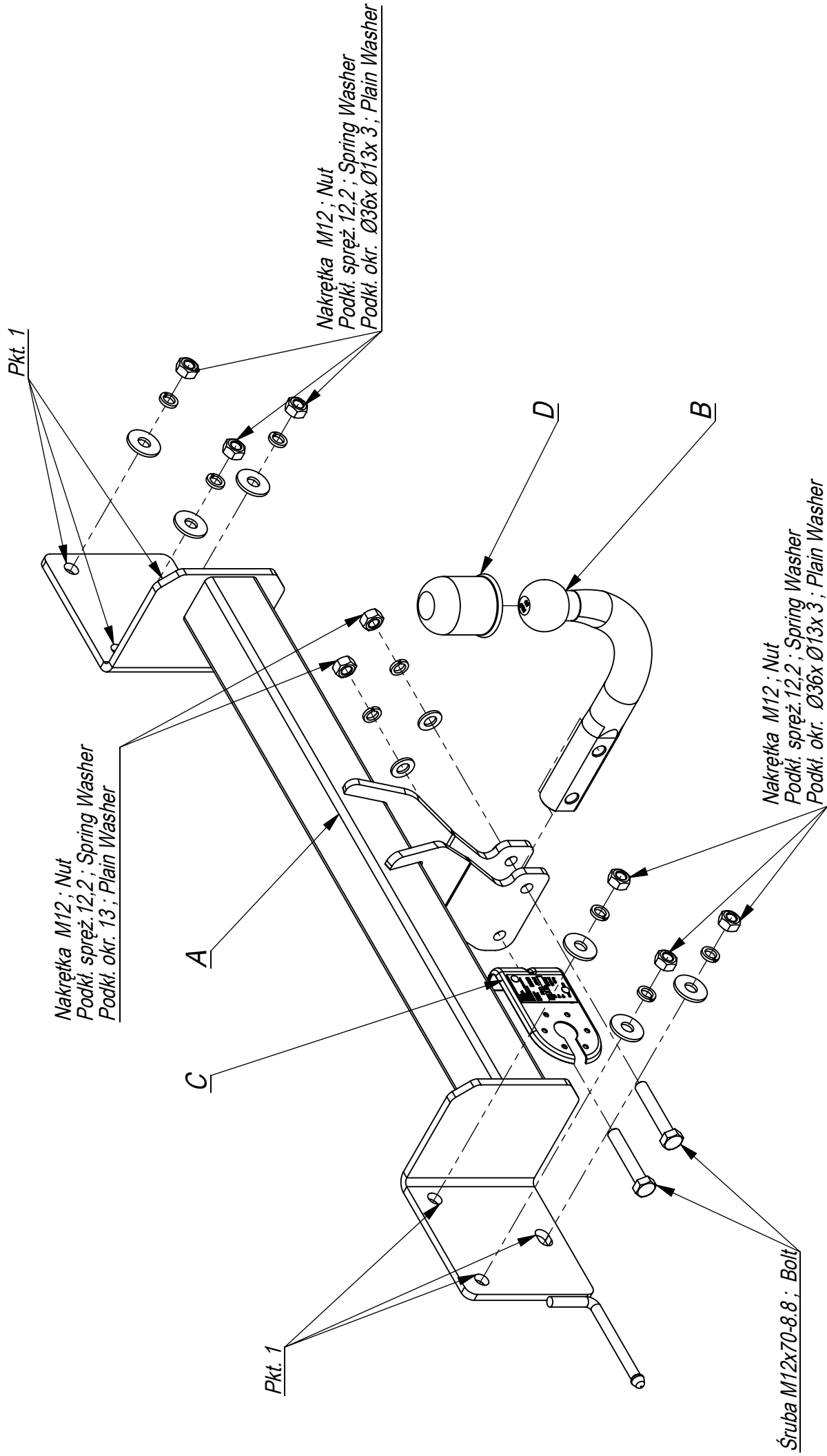

- Odkręcamy zderzak i lampy.
- Demontujemy belkę zderzeniową (nie będzie już potrzebna).
- Zdejmujemy gumowe mocowanie tłumika.
- Montujemy belkę haka A poprzez nakrętki po odkręconej wcześniej belce.
- Tłumik podwieszamy przez gumowe mocowanie zdjęte wcześniej zakładając je na pręt przyspawany do haka.
- Dokręcić wszystkie śruby z momentem według tabeli.
- Dokręcić kulę i blachę gniazda elektrycznego.
- Podłączyć instalację elektryczną.

- Unscrew the bumper.
- Unscrew the bumper bar (it will not be used any more).
- Lower the damper from the hanger.
- Put the main bar A to the rear belt and screw with nuts (point 1).
- Assemble the damper, bumper and lights.
- Fix the ball and electric plate with bolts M12x70 8.8.
- Tighten all the bolts according to the torque setting- see the table.
- Connect the electric wires.

- Dévisser le pare-chocs.
- Dévisser la poutre de chocs (elle ne sera plus utilisée).
- Abaisser le silencieux du poinçon.
- Mettre la poutre du crochet d'attelage A à la bande postérieure et serrer avec les écrous (point 1).
- Monter le silencieux, le pare-chocs et les lampes.
- Visser le crochet d'attelage et socle de prise électrique à l'aide des boulons M12x70 8.8.
- Serrer tous les boulons avec un couple de serrage selon tableau.
- Raccorder le circuit électrique.

