



1999 - 2006

CITROEN XSARA PICASSO

Cat. No. C/014

e20

e20*94/20*0920*00

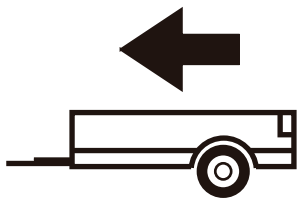

1300Kg



80Kg

D = 7,56kN

D (kN) =



MAX kg

x

MAX kg

x 0,00981



MAX kg

+

MAX kg

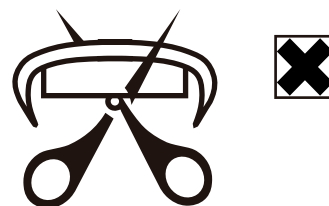
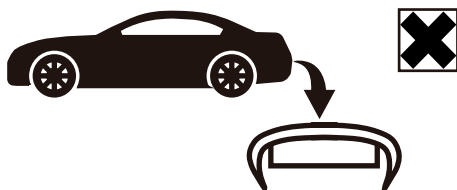

IMIOLA HAK-POL

96-111 KOWIESY, CHOJNATA 23A, POLAND

tel. +48 46 831 73 31, fax +48 831 74 29

e-mail: office@imiola.pl, www.imiola.pl

PRZEKRÓJ A-A

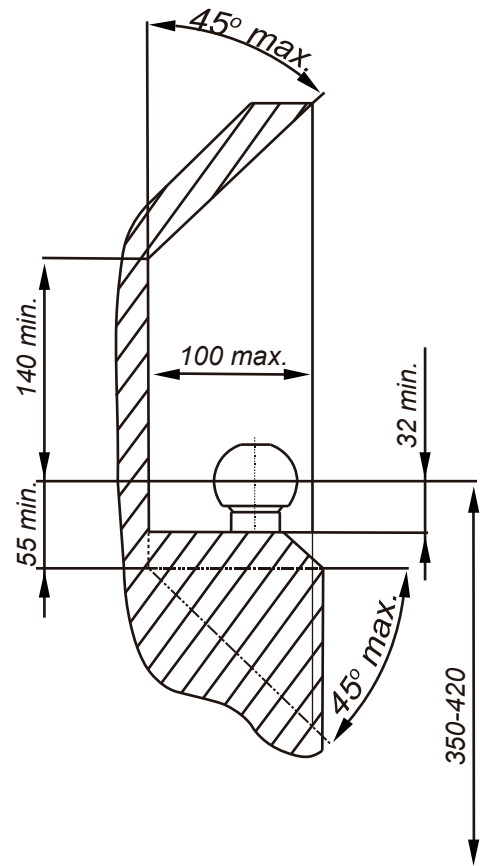
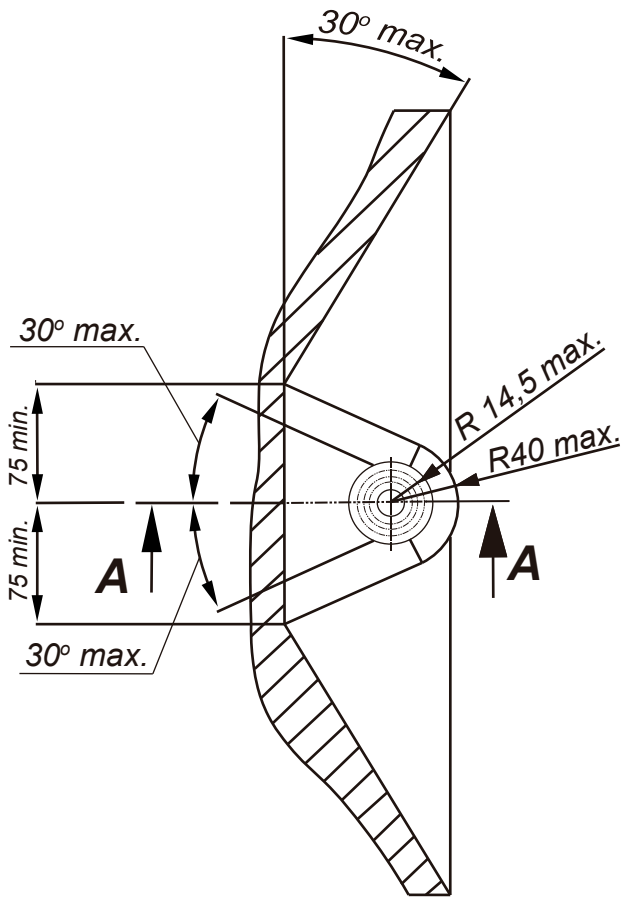

PL Należy zagwarantować przestrzeń swobodną według załącznika VII, rysunek 25a/b Regulaminu EKG ONZ 55.01 przy dopuszczalnym ciężarze całkowitym pojazdu.

F L'espace libre doit être garanti conformément à l'annexe VII, illustration de la réglementation 55.01 CE pour un poids total en charge autorisé du véhicule.







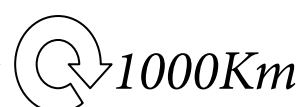

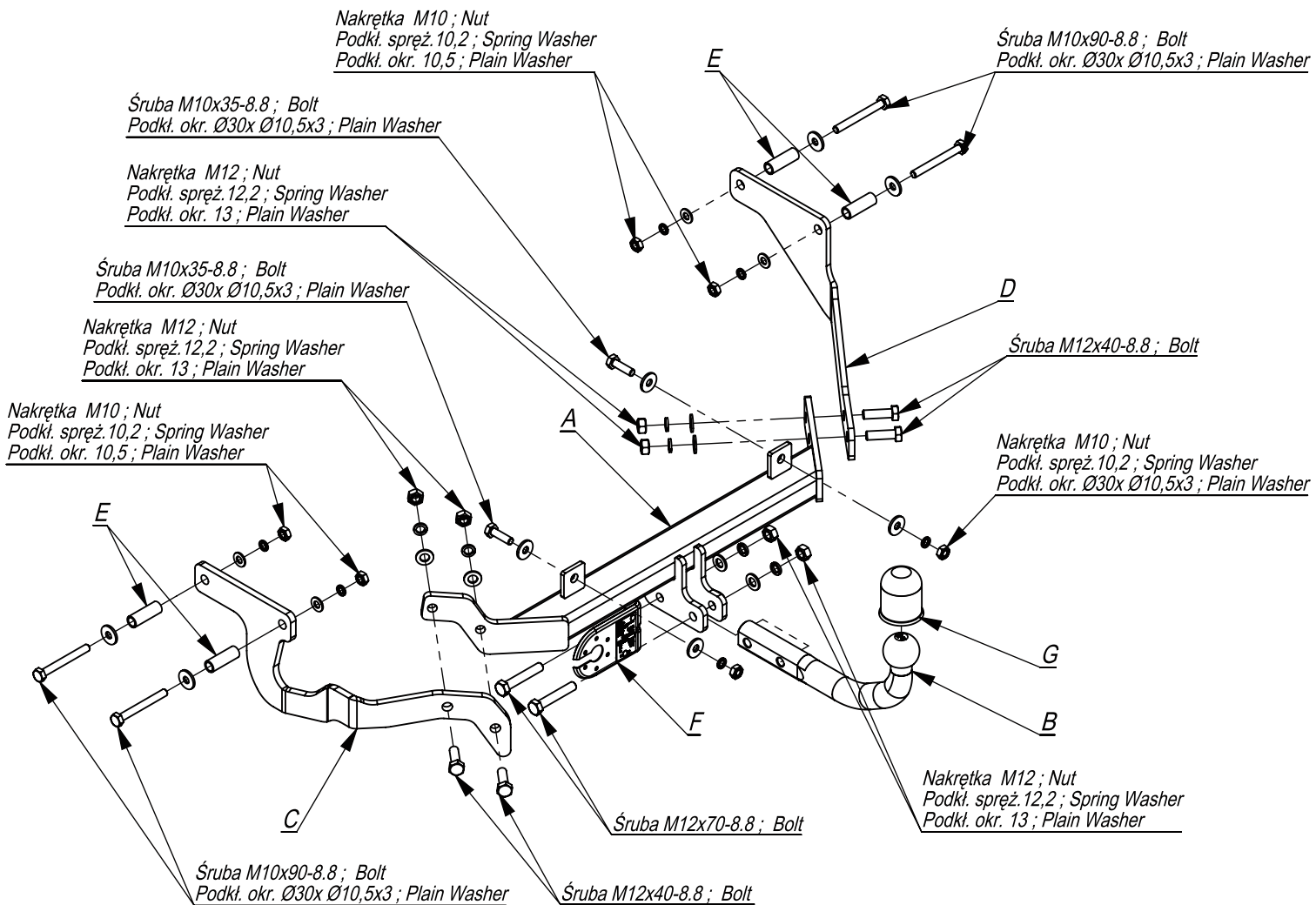

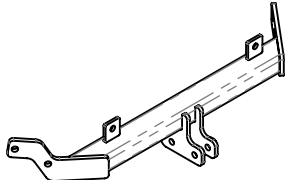
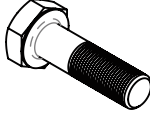
GB The clearance specified in appendix VII, diagram 25a/b of Regulation No. 55.01 UN EU must be guaranteed at laden weight of the vehicle.

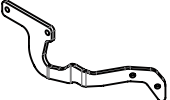
D Der Freiraum nach Anhang VII, Abbildung 25a/b der Vorschriften 55.01 EG ist zu gew 25a/bahrleisten bei zulässigem Gesamtgewicht des Fahrzeuges.

Moment skracający dla śrub i nakrętek (8.8) Torgue settings for nuts and bolts (8.8)	
M8	25Nm
M10	55Nm
M12	85Nm
M14	135Nm
M16	195Nm





	A	x1		M12x70	2
				M12x40	4
				M10x90	4
				M10x35	2
	B	x1		M12	6
				M10	6
	C	x1		Ø30xØ10,5x3	8
	D	x1		13	6
	E	x4		10,5	4
	F	x1		12,2	6
				10,2	6
	G	x1			

Nakrętka M10 ; Nut
 Podkł. spręż. 10,2 ; Spring Washer
 Podkł. okr. 10,5 ; Plain Washer

Śruba M10x35-8.8 ; Bolt
 Podkł. okr. Ø30x Ø10,5x3 ; Plain Washer

Nakrętka M12 ; Nut
 Podkł. spręż. 12,2 ; Spring Washer
 Podkł. okr. 13 ; Plain Washer

Śruba M10x35-8.8 ; Bolt
 Podkł. okr. Ø30x Ø10,5x3 ; Plain Washer

Nakrętka M12 ; Nut
 Podkł. spręż. 12,2 ; Spring Washer
 Podkł. okr. 13 ; Plain Washer

Nakrętka M10 ; Nut
 Podkł. spręż. 10,2 ; Spring Washer
 Podkł. okr. 10,5 ; Plain Washer

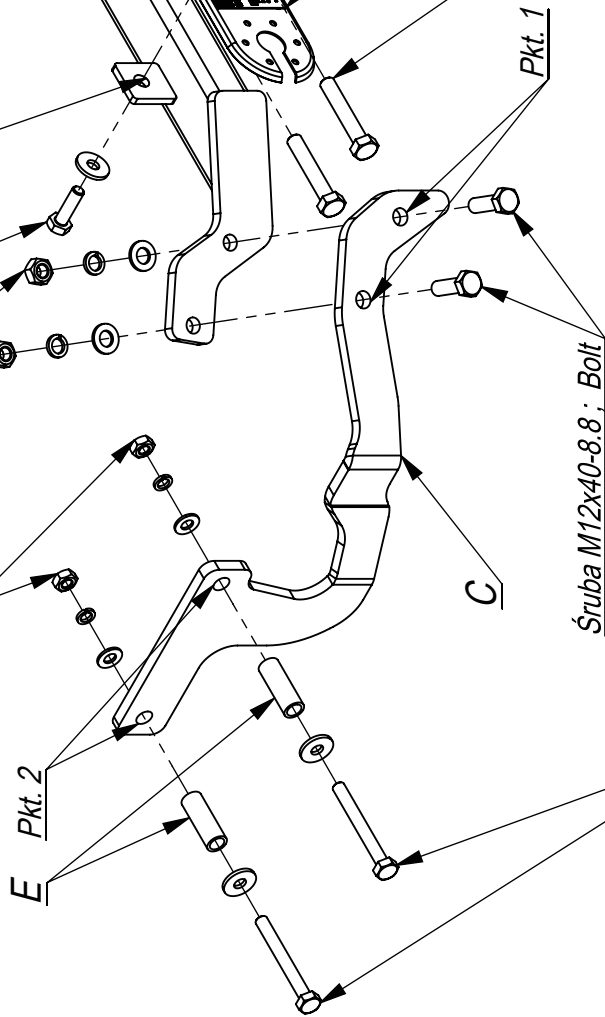

Śruba M12x40-8.8 ; Bolt

Śruba M10x90-8.8 ; Bolt
 Podkł. okr. Ø30x Ø10,5x3 ; Plain Washer

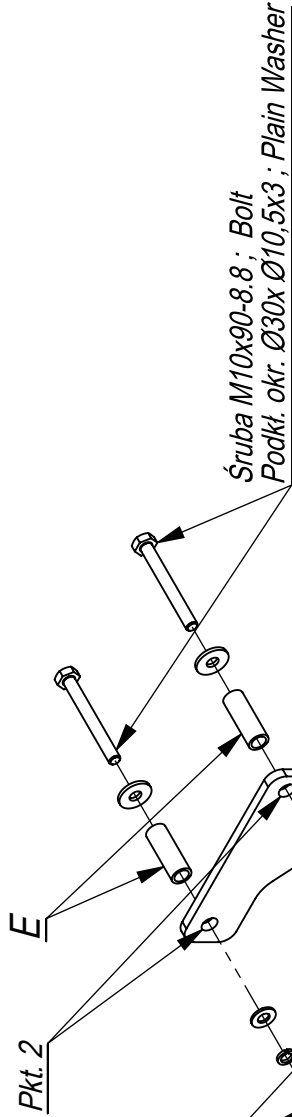

Śruba M10x90-8.8 ; Bolt
 Podkł. okr. Ø30x Ø10,5x3 ; Plain Washer

Śruba M12x40-8.8 ; Bolt

Nakrętka M10 ; Nut
 Podkł. spręż. 10,2 ; Spring Washer
 Podkł. okr. Ø30x Ø10,5x3 ; Plain Washer

Nakrętka M12 ; Nut
 Podkł. spręż. 12,2 ; Spring Washer
 Podkł. okr. 13 ; Plain Washer

Śruba M12x70-8.8 ; Bolt

Śruba M12x40-8.8 ; Bolt

Śruba M10x90-8.8 ; Bolt
 Podkł. okr. Ø30x Ø10,5x3 ; Plain Washer

- Odkręcić koło zapasowe.
- W technologiczne otwory, w podłużnicach włożyć tuleje dystansowe.
- Elementy haka C i D przykręcić lekko do podłużnic śrubami M10x90 8.8 (pkt 2).
- Przez otwory w tylnym pasie przykręcić lekko belkę haka śrubami M10x35 8.8 (pkt 3).
- Elementy haka C i D przykręcić do belki haka A śrubami M12x35 8.8 (pkt 1).
- Dokręcić wszystkie śruby z momentem wg tabeli.
- Przykręcić kulę i blachę gniazda elektrycznego śrubami M12x70 8.8 (pkt 4).
- Podłączyć instalację elektryczną.
- Zamontować koło zapasowe.

- Unscrew the spare wheel.
- Insert distance sleeves in the technological holes of the metal clamps.
- Screw slightly elements C and D to the metal clamps with bolts M10x90 8.8 (point 2).
- Screw slightly the main bar, through the holes in the rear belt, with bolts M10x35 8.8 (point 3).
- Screw the elements C and D to the main bar A with bolts M12x35 8.8 (point 1).
- Tighten all the bolts according to the torque setting- see the table.
- Fix the ball and electric plate with bolts M12x70 8.8 (point 4).
- Connect the electric wires.
- Assemble the spare wheel.

- Desserrer la roue de secours,
- Placer les douilles d'écartement dans les ouvertures de longerons,
- Serrez légèrement les éléments de Rochet C et D aux longerons par les boulons M10x90 8.8 (point 2).
- Serrez légèrement le socle du crochet par les ouvertures de ceinture arrière par les boulons M10x35 8.8 (point 3).
- Serrez les éléments du crochet C et D au socle du Rochet A par les boulons M12x35 8.8 (point 1).
- Serrer tous les boulons avec un couple de serrage selon tableau,
- Visser le crochet d'attelage et socle de prise électrique par les boulons M12x70 8.8 (point 4).
- Raccorder le circuit électrique.
- Desserrer la roue de secours.

