



2013 -

FORD TRANSIT CUSTOM

Cat. No. **E/049**

e20

E20 55R-01

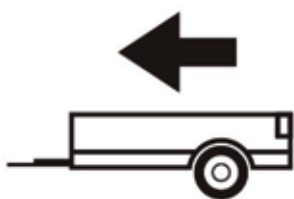

2800Kg



115Kg

D = 15,40kN

D (kN) =



MAX kg

x

MAX kg

x 0,00981



MAX kg

+

MAX kg



IMIOLA HAK-POL

96-111 KOWIESY, CHOJNATA 23A, POLAND

tel. +48 46 831 73 31, fax +48 831 74 29

e-mail: office@imiola.pl, www.imiola.pl

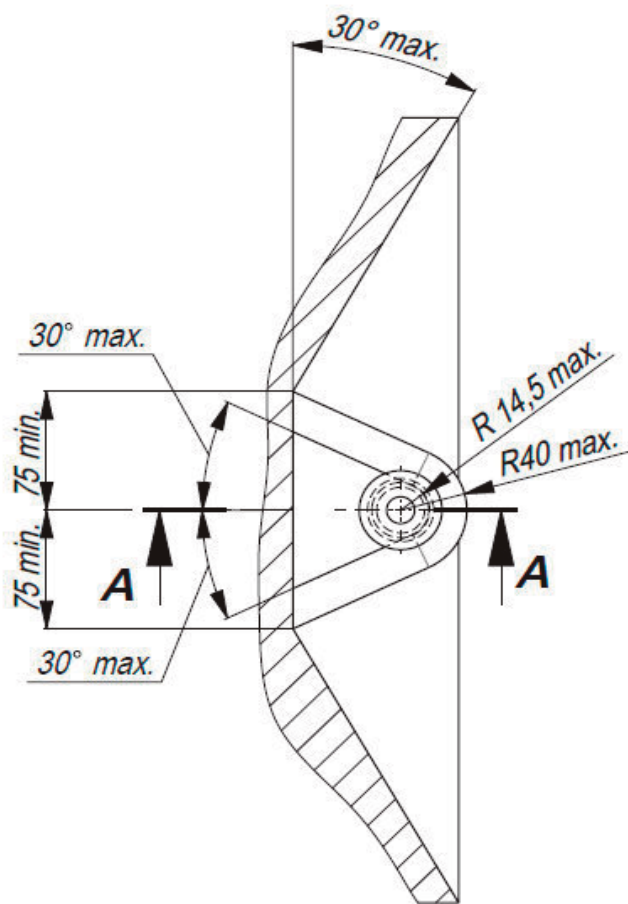

PRZEKRÓJ A-A

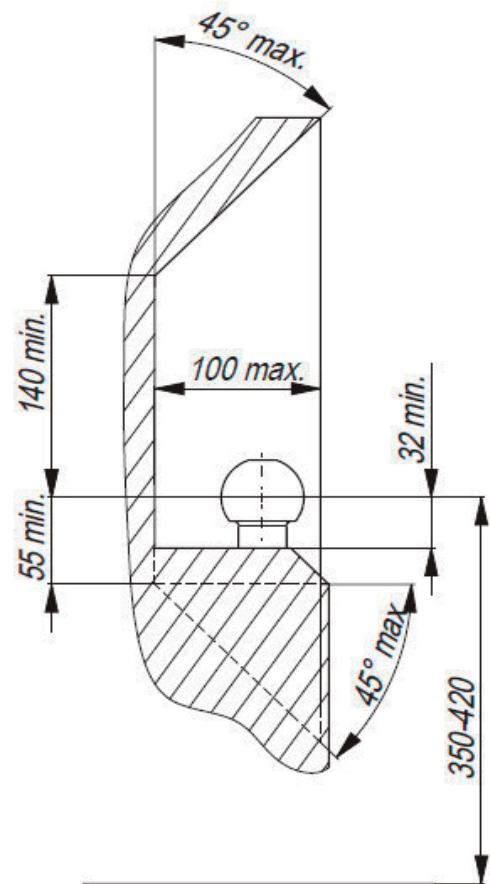

PL Należy zagwarantować przestrzeń swobodną według załącznika VII, rysunek 25a/b Regulaminu EKG ONZ 55.01 przy dopuszczalnym ciężarze całkowitym pojazdu.

F L'espace libre doit être garanti conformément à l'annexe VII, illustration de la réglementation 55.01 CE pour un poids total en charge autorisé du véhicule.

GB The clearance specified in appendix VII, diagram 25a/b of Regulation No. 55.01 UN EU must be guaranteed at laden weight of the vehicle.

D Der Freiraum nach Anhang VII, Abbildung 25a/b der Vorschriften 55.01 EG ist zu gew 25a/b abhristen bei zulässigem Gesamtgewicht des Fahrzeuges

Moment skręcający dla śrub i nakrętek (8.8)
Torque settings for nuts and bolts (8.8)

M8	25Nm
M10	55Nm
M12	85Nm
M14	135Nm
M16	195Nm



Śruba M12x100-8.8; Bolt
 Podkł. spręż. 12,2; Spring Washer
 Podkł. okr. Ø36x Ø13x 3; Plain Washer
 Podkł. okr. Ø36x Ø13x 3; Plain Washer

Nakrętka M12; Nut
 Podkł. spręż. 12,2; Spring Washer
 Podkł. okr. 13; Plain Washer







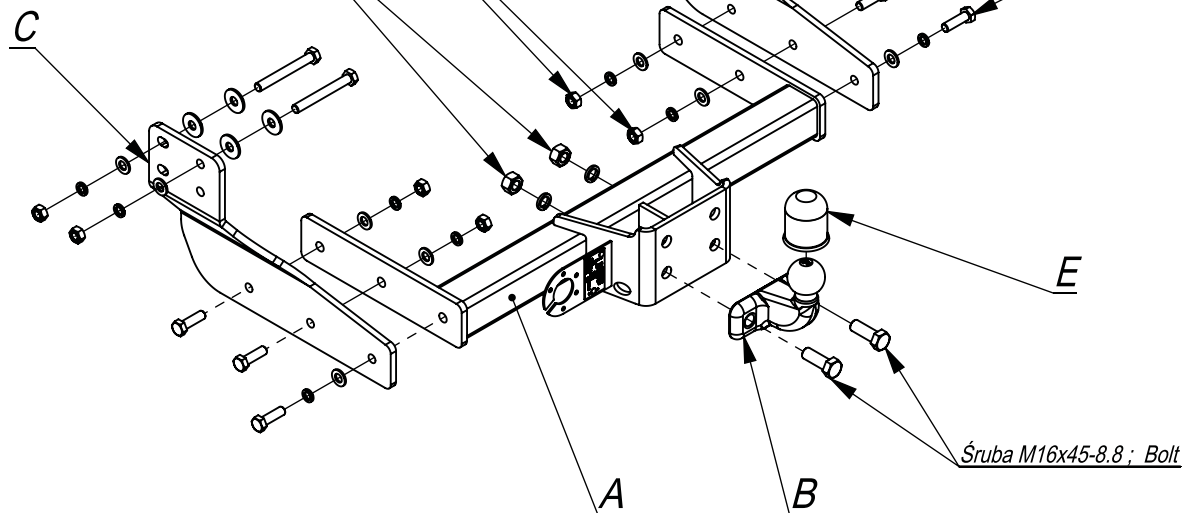

Nakrętka M12; Nut
 Podkł. spręż. 12,2; Spring Washer
 Podkł. okr. 13; Plain Washer

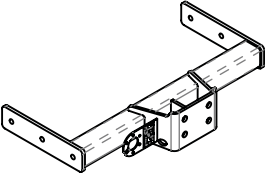
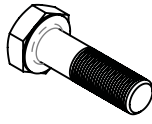
Śruba M12x40-8.8; Bolt

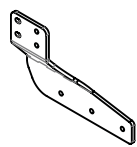
Nakrętka M16; Nut
 Podkł. spręż. 16,3; Spring Washer
 Podkł. okr. 17; Plain Washer

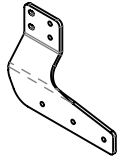
Śruba M12x40-8.8; Bolt
 Podkł. spręż. 12,2; Spring Washer
 Podkł. okr. 13; Plain Washer



	A	x1		M16x45	2
				M12x100	4
				M12x40	6
	B	x1		M16	2
				M12	8
	C	x1		Ø36xØ13x3	8
				17	2
	D	x1		13	10
				16,3	2
	E	x1		12,2	10

Nakrętka M12; Nut
 Podkł. spręż. 12,2; Spring Washer
 Podkł. okr. 13; Plain Washer

Śruba M12x40-8.8; Bolt

Śruba M12x40-8.8; Bolt
 Podkł. spręż. 12,2; Spring Washer
 Podkł. okr. 13; Plain Washer

Śruba M16x45-8.8; Bolt

Śruba M12x100-8.8; Bolt
 Podkł. spręż. 12,2; Spring Washer
 Podkł. okr. Ø36x Ø13x 3; Plain Washer
 Podkł. okr. Ø36x Ø13x 3; Plain Washer

Nakrętka M12; Nut
 Podkł. spręż. 12,2; Spring Washer
 Podkł. okr. 13; Plain Washer

Nakrętka M16; Nut
 Podkł. spręż. 16,3; Spring Washer
 Podkł. okr. 17; Plain Washer

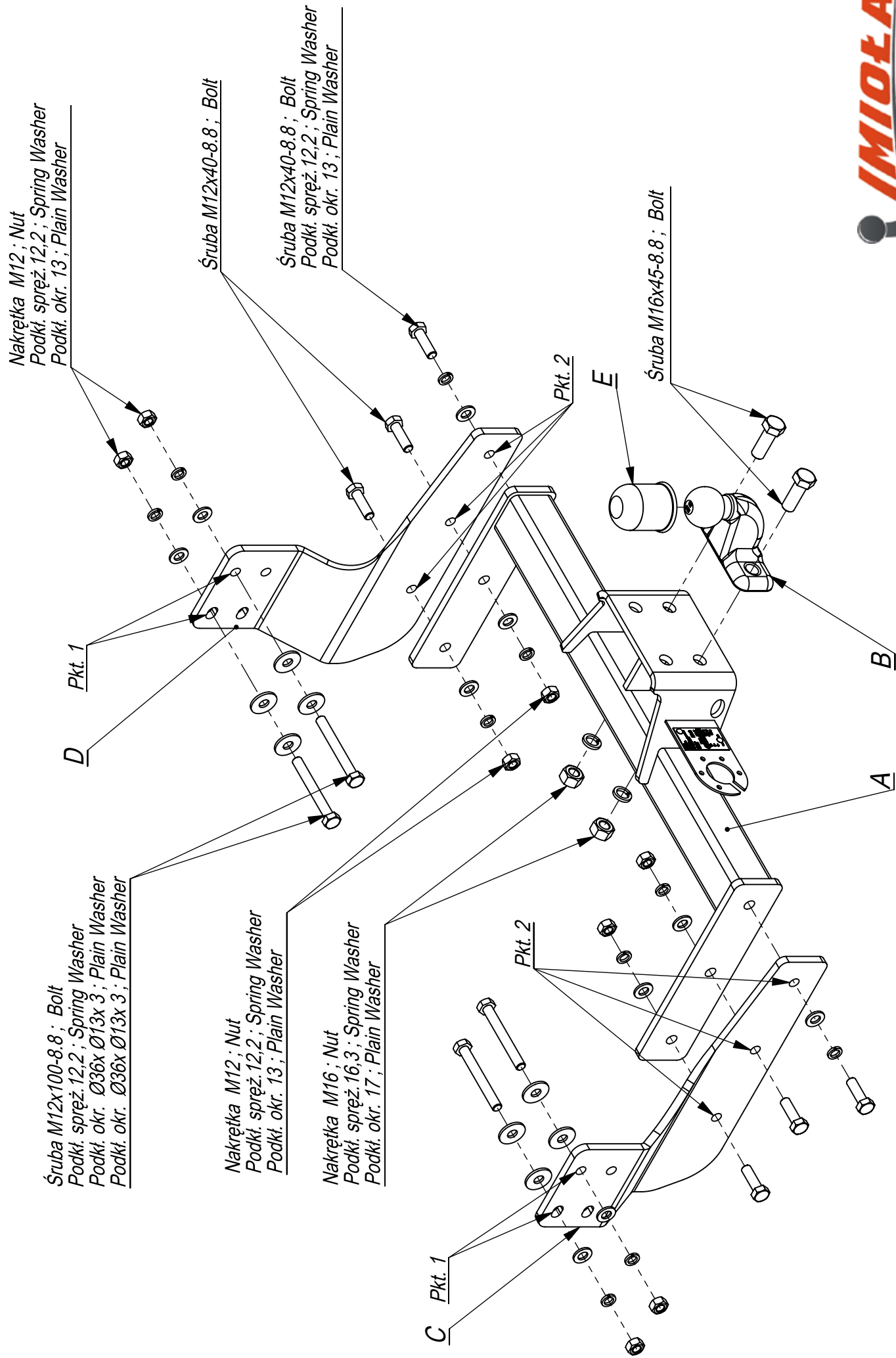

- Odkręcić śruby mocujące ucho holownicze.
- Elementy haka C i D przykręcić do podłużnic poprzez technologiczne otwory śrubami M12x100 8.8 (pkt1) wykorzystując śruby fabryczne.
- Do elementów C i D przykręcić belkę haka A śrubami M12x40 8.8 (pkt 2).
- Przykręcić kulę haka śrubami M16x45 8.8 (pkt 3).
- Dokręcić wszystkie śruby z momentem jak w tabeli.
- Podłączyć instalację elektryczną.

- Screw the elements C to the metal clamps, through the technological holes, with bolts M12x100 8.8 using the elements D (point 1).
- Screw the main bar A to the elements C with bolts M12x35 8.8 (point 2).
- Fix the ball with bolts M16x45 8.8 (point 3).
- Tighten all the bolts according to the torque setting- see the table.
- Connect the electric wires.

- Dévisser les boulons fixant l'anneau d'attelage.
- Visser les éléments C et D aux longerons à travers les trous technologiques avec les boulons M12x100 8.8 (point1) en utilisant les boulons d'origine.
- Serrer la poutre du crochet d'attelage avec les éléments C et D à l'aide des boulons M12x40 8.8 (point 2).
- Visser la boule à l'aide des vis M16x45 8.8 (point 3).
- Serrer tous les boulons avec un couple de serrage selon tableau.
- Raccorder le circuit électrique.

