



03/2008 -

JEEP CHEROKEE

Cat. No. J/050

e20

e20*94/20**00

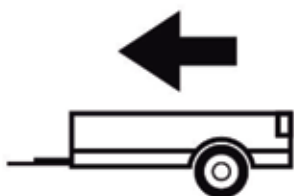

3500Kg



350Kg

D = 15,20kN

D (kN) =



MAX kg

x

MAX kg

x 0,00981



MAX kg

+

MAX kg



IMIOLA HAK-POL

96-111 KOWIESY, CHOJNATA 23A, POLAND

tel. +48 46 831 73 31, fax +48 831 74 29

e-mail: office@imiola.pl, www.imiola.pl

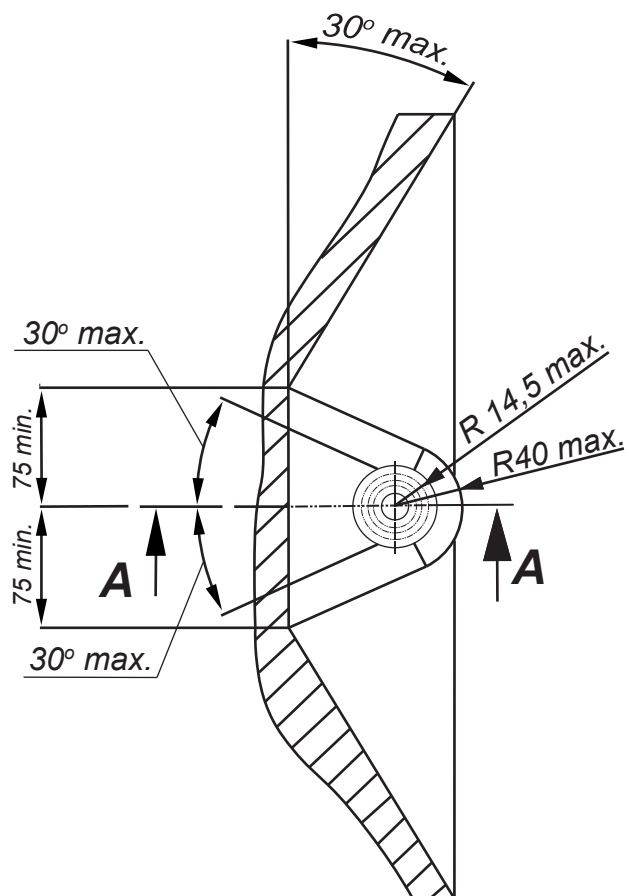

PRZEKRÓJ A-A

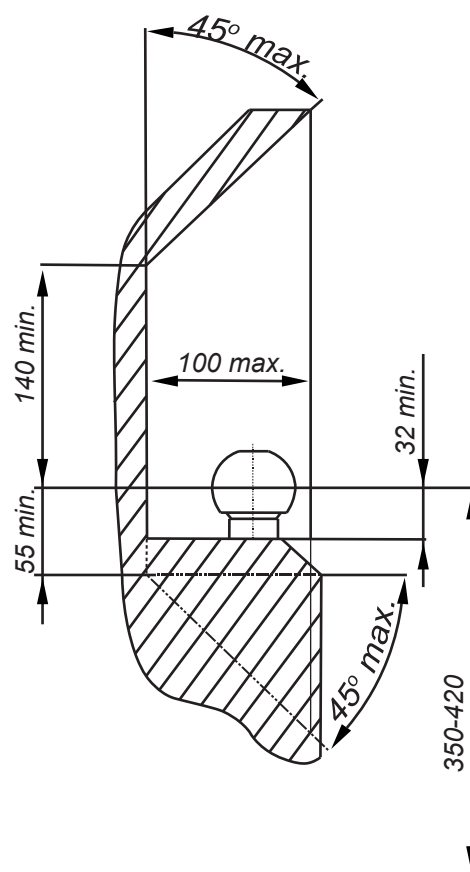

PL Należy zagwarantować przestrzeń swobodną według załącznika VII, rysunek 25a/b Regulaminu EKG ONZ 55.01 przy dopuszczalnym ciężarze całkowitym pojazdu.

F L'espace libre doit être garanti conformément à l'annexe VII, illustration de la réglementation 55.01 CE pour un poids total en charge autorisé du véhicule.







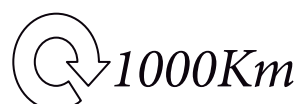

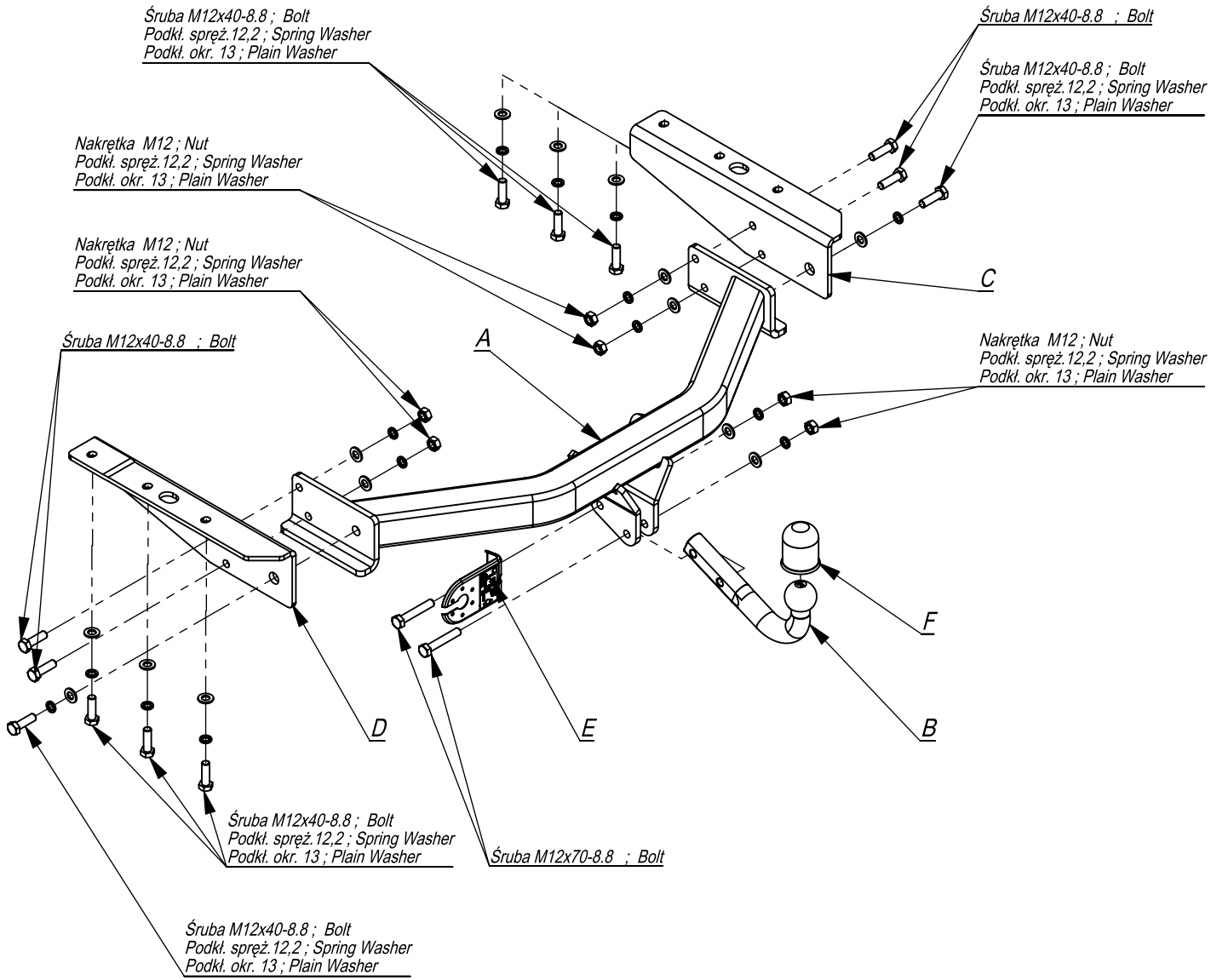

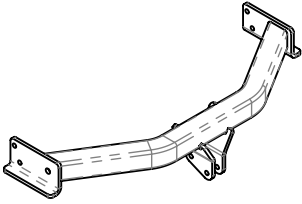
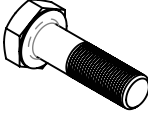
GB The clearance specified in appendix VII, diagram 25a/b of Regulation No. 55.01 UN EU must be guaranteed at laden weight of the vehicle.

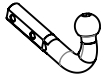
D Der Freiraum nach Anhang VII, Abbildung 25a/b der Vorschriften 55.01 EG ist zu gewährleisten bei zulässigem Gesamtgewicht des Fahrzeuges.

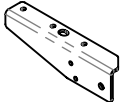
Moment skracający dla śrub i nakrętek (8.8) Torque settings for nuts and bolts (8.8)	
M8	25Nm
M10	55Nm
M12	85Nm
M14	135Nm
M16	195Nm

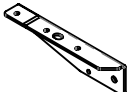



	A	x1		M12x70	2
				M12x45	12
	B	x1		M12	6
	C	x1		13	14
	D	x1		12,2	14
	E	x1			
	F	x1			

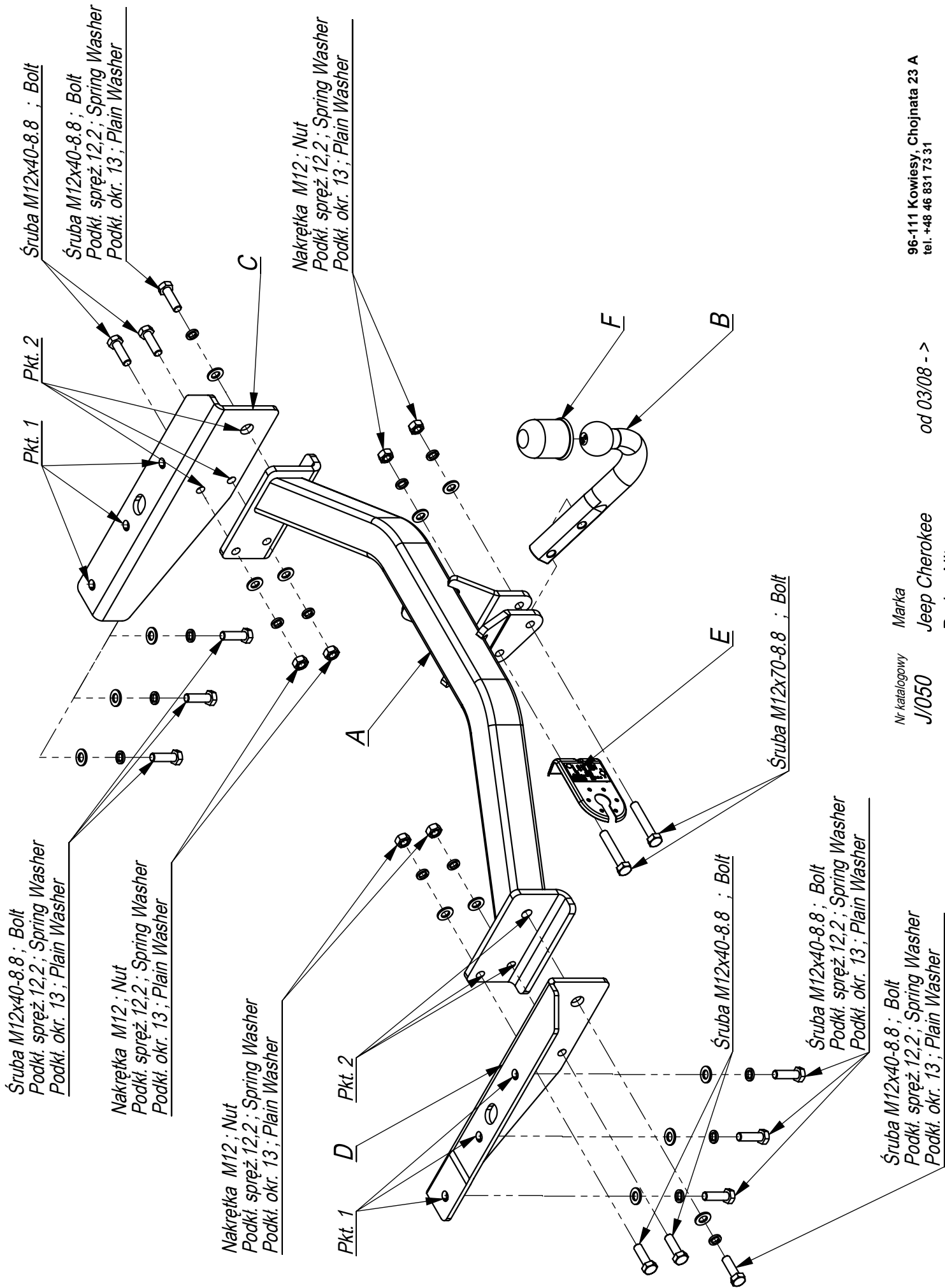

- Odkręcić koło zapasowe, zderzak i osłony nadkoli.
- Odkręcić lewe ucho holownicze.
- Zrobić wycięcie w tylnym pasie 70x650.
- Elementy C i D przykręcić do podłużnic śrubami M12x40 (pkt 1).
- Belkę haka A wsunąć między elementy i przykręcić śrubami M12x40 (pkt 2).
- Wyciąć w zderzaku dolnej części, w jego osi fragment .
- Założyć zderzak i osłony nadkoli.
- Dokręcić wszystkie śruby z momentem według tabeli.
- Dokręcić kulę i blachę gniazda elektrycznego.
- Podłączyć instalację elektryczną.

- Unscrew the spare wheel, bumper and shields of the inner wheel arches.
- Unscrew the left towing eye.
- Cut out the fragment 70x650 in the rear belt.
- Elements C and D screw to the frame side members with bolts M12x40 8.8 (point 1).
- Insert the main bar A between the elements and screw with bolts M12x40 8.8 (point 2).
- Cut out the fragment in the lower part of the bumper, in its axle.
- Mount the bumper and shields of the inner wheel arches.
- Tighten all the bolts according to the torque setting- see the table.
- Fix the ball and electric plate.
- Connect the electric wires.

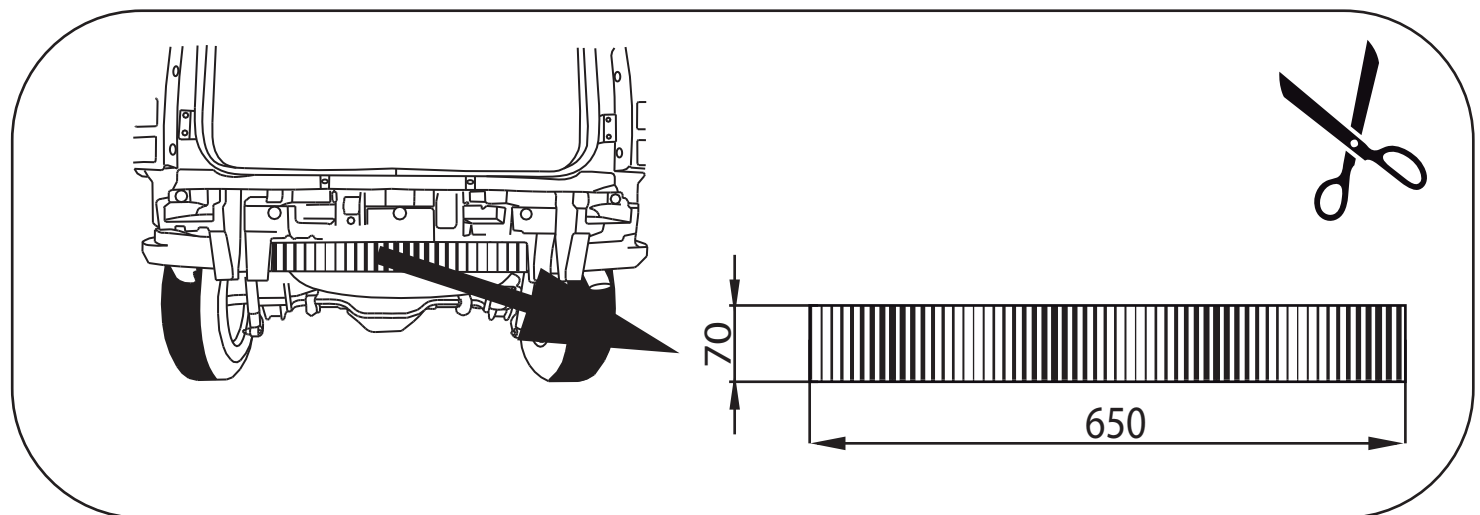
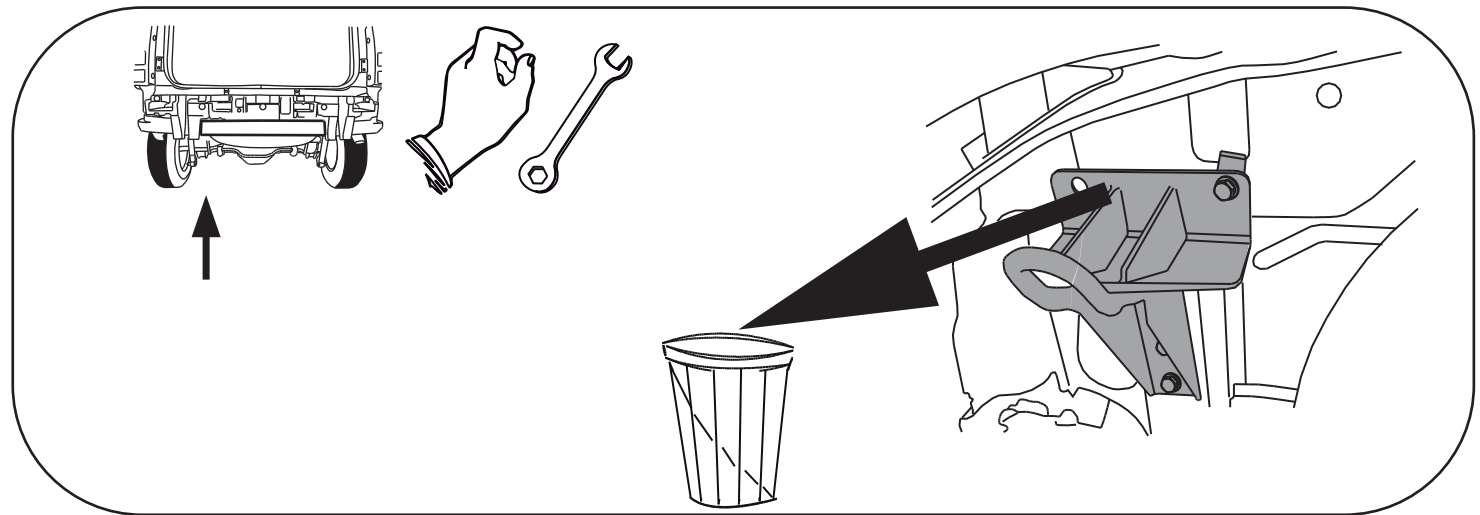
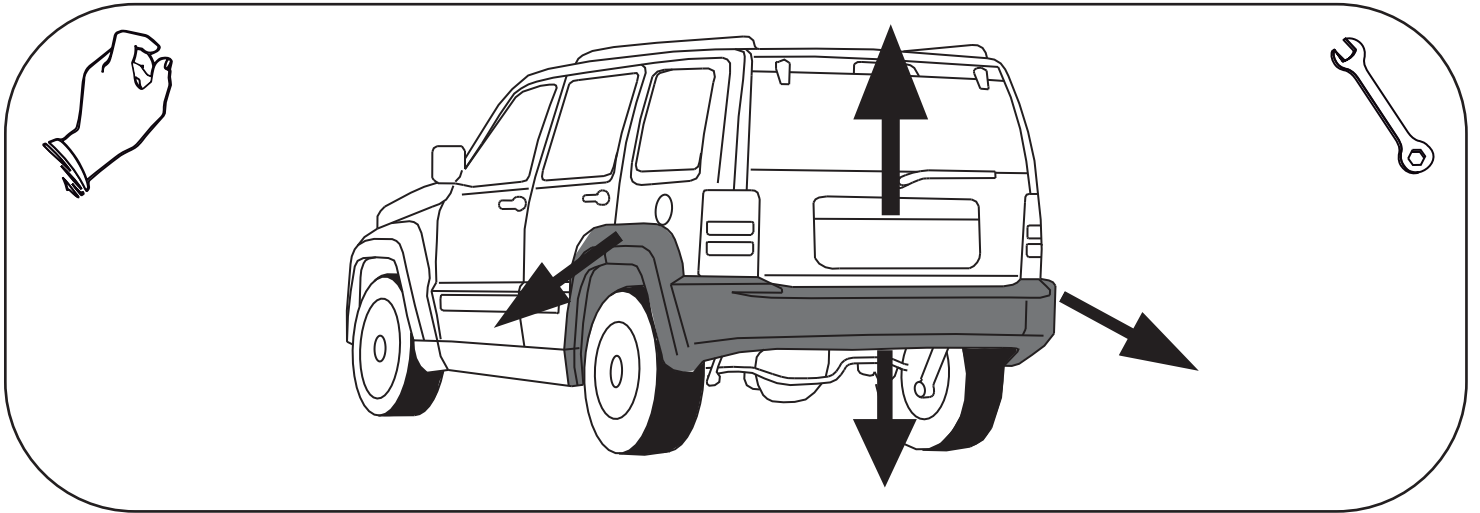
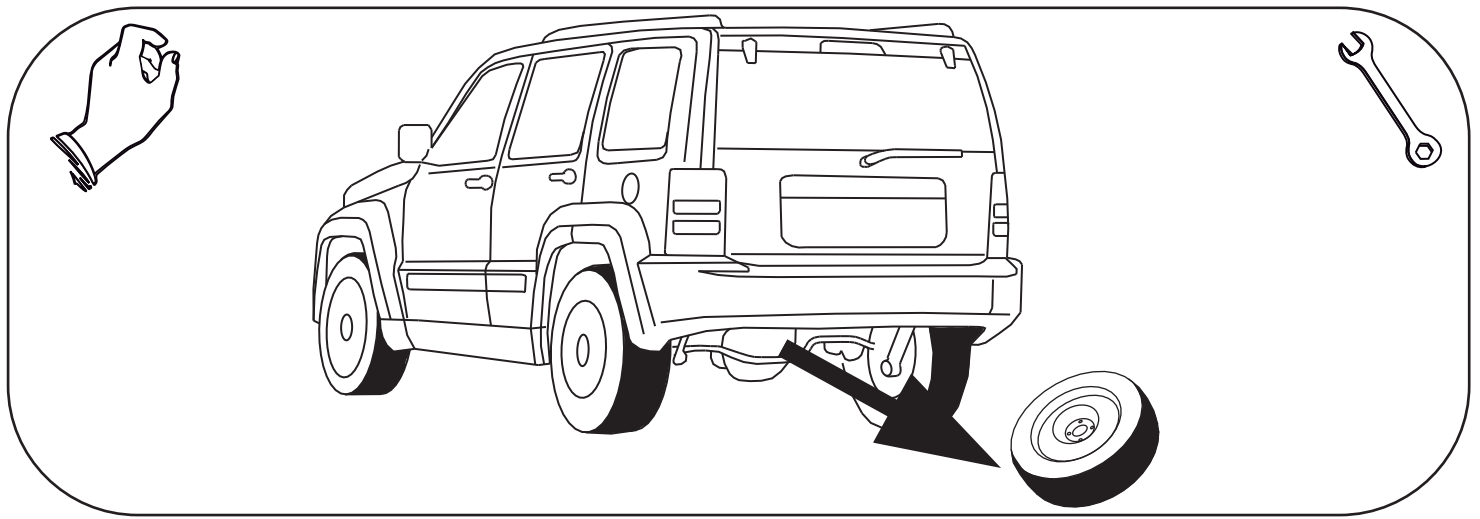

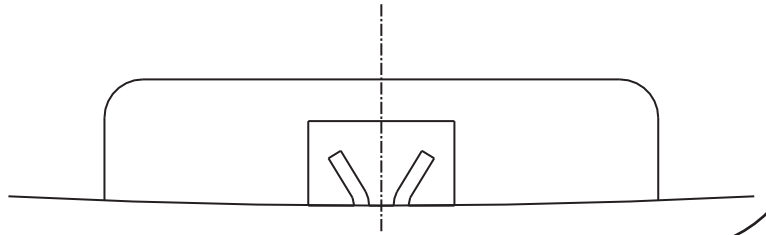
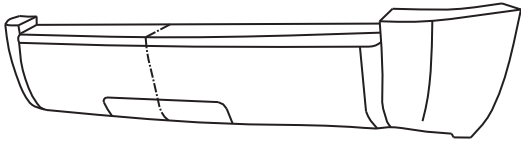

DODGE NITRO

RYS. 1

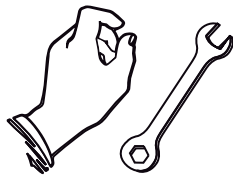
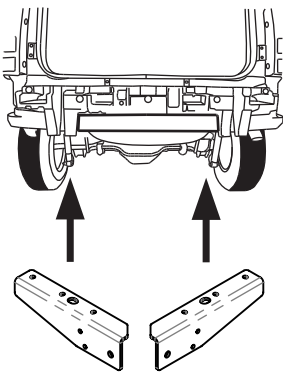
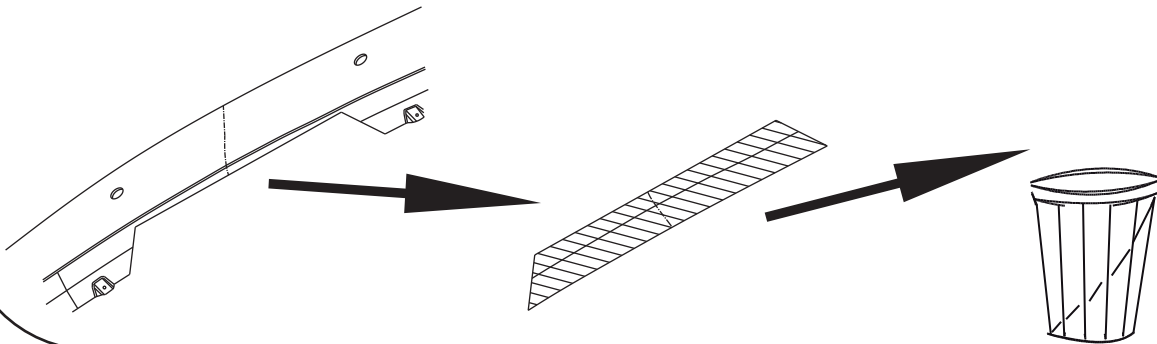

JEEP CHEROKEE



 M12x40 x6

 12,2 x6

 13 x6

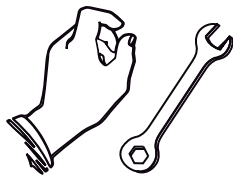
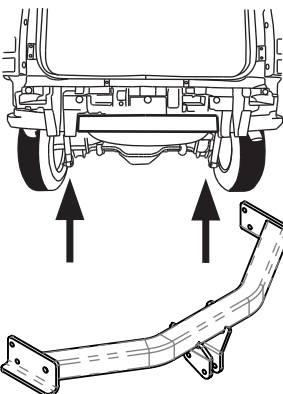
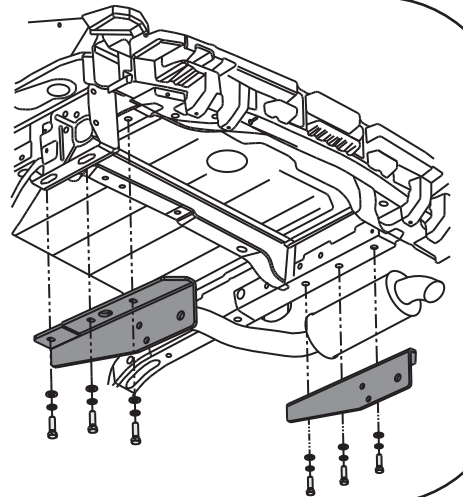

 M12x40 x6

 12,2 x6

 13 x6

 M12 x4

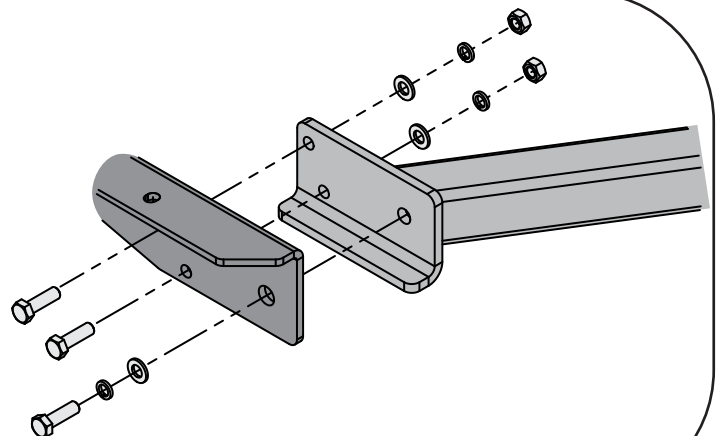

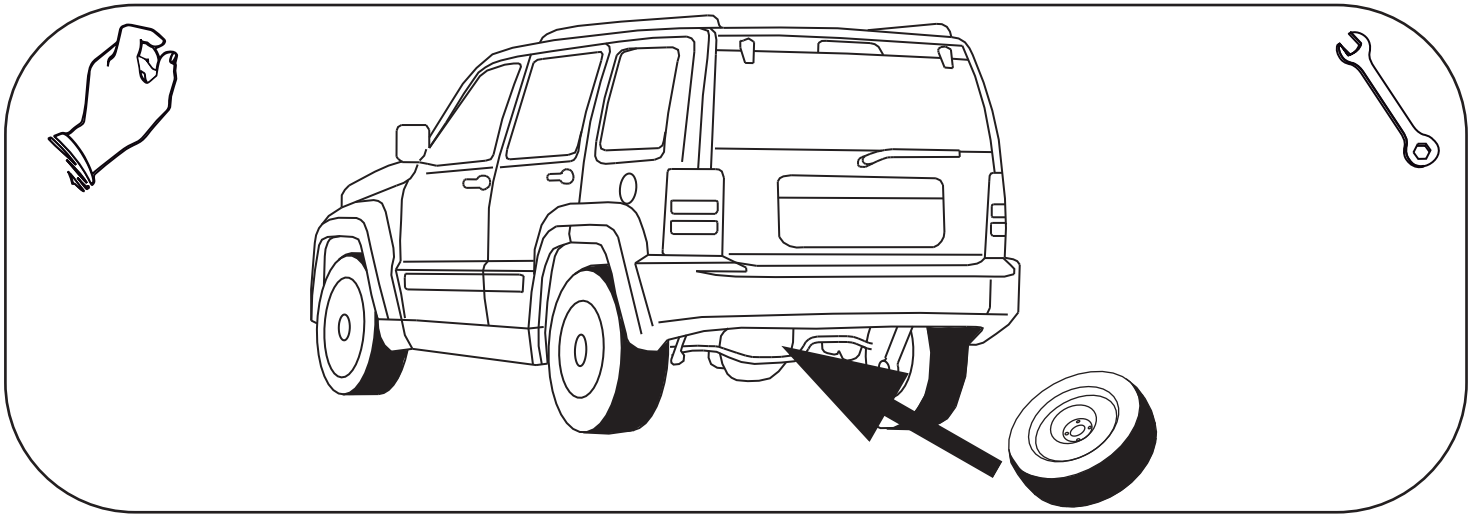
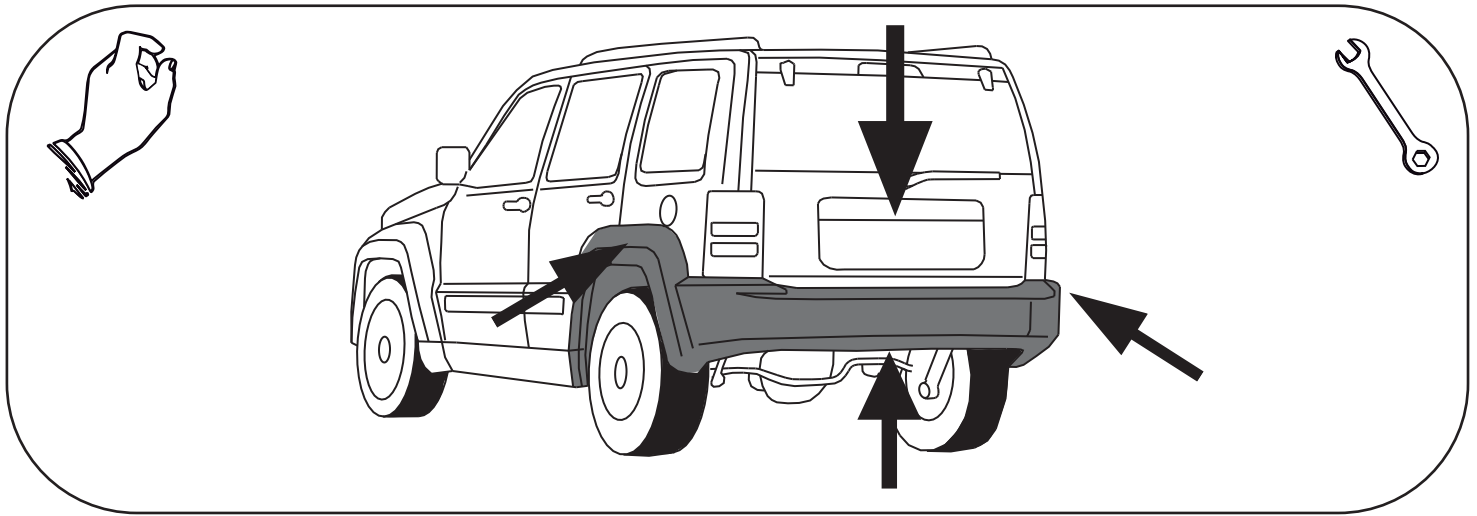
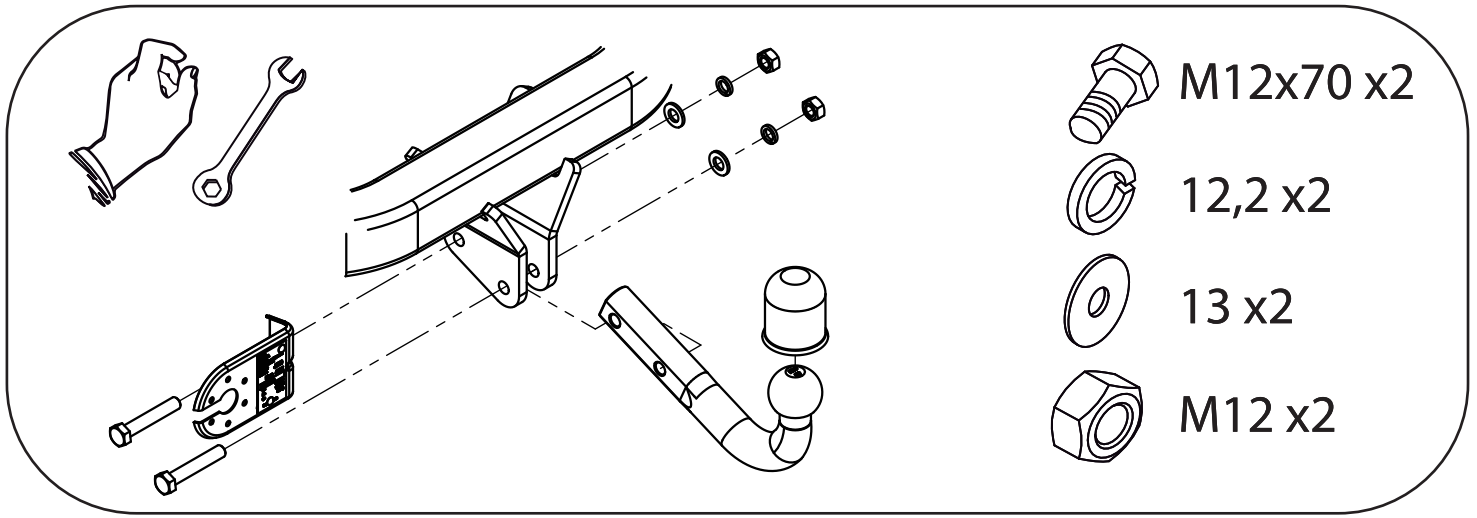

DODGE NITRO

RYS. 1

