



2007 -

KIACEE'D com.

Cat. No. K/023

e20

e20*94/20*0785*00



1600Kg



75Kg

D = 8,85kN

$$D \text{ (kN)} = \frac{\text{MAX kg} \times \text{MAX kg}}{\text{MAX kg} + \text{MAX kg}} \times 0,00981$$



IMIOLA HAK-POL

96-111 KOWIESY, CHOJNATA 23A, POLAND

tel. +48 46 831 73 31, fax +48 831 74 29

e-mail: office@imiola.pl, www.imiola.pl

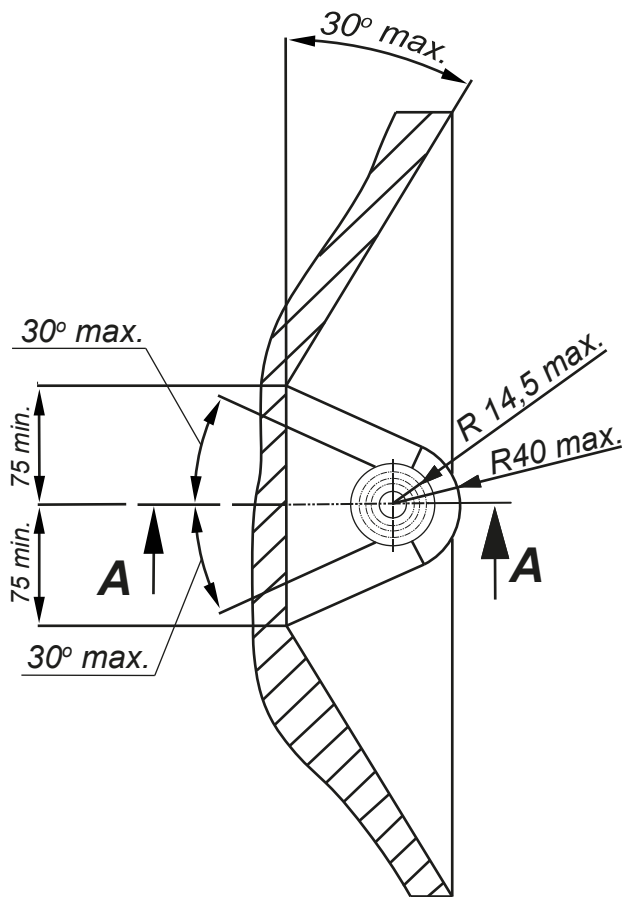

PRZEKRÓJ A-A

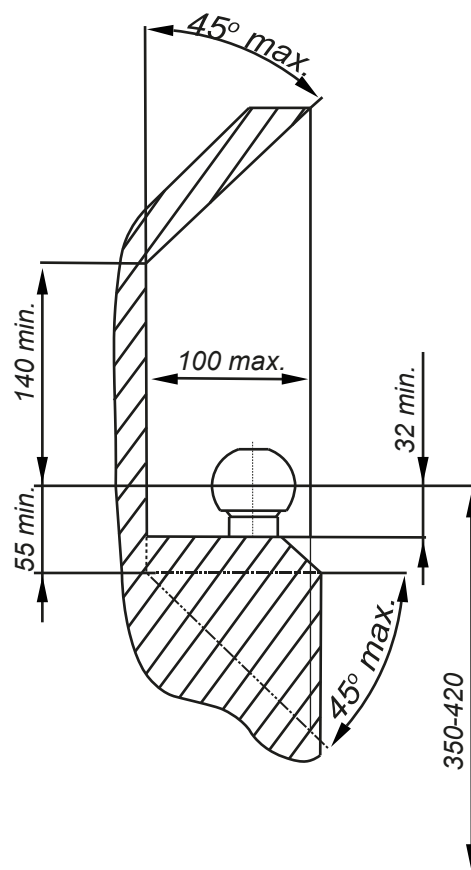

PL Należy zagwarantować przestrzeń swobodną według załącznika VII, rysunek 25a/b Regulaminu EKG ONZ 55.01 przy dopuszczalnym ciężarze całkowitym pojazdu.

F L'espace libre doit être garanti conformément à l'annexe VII, illustration de la réglementation 55.01 CE pour un poids total en charge autorisé du véhicule.







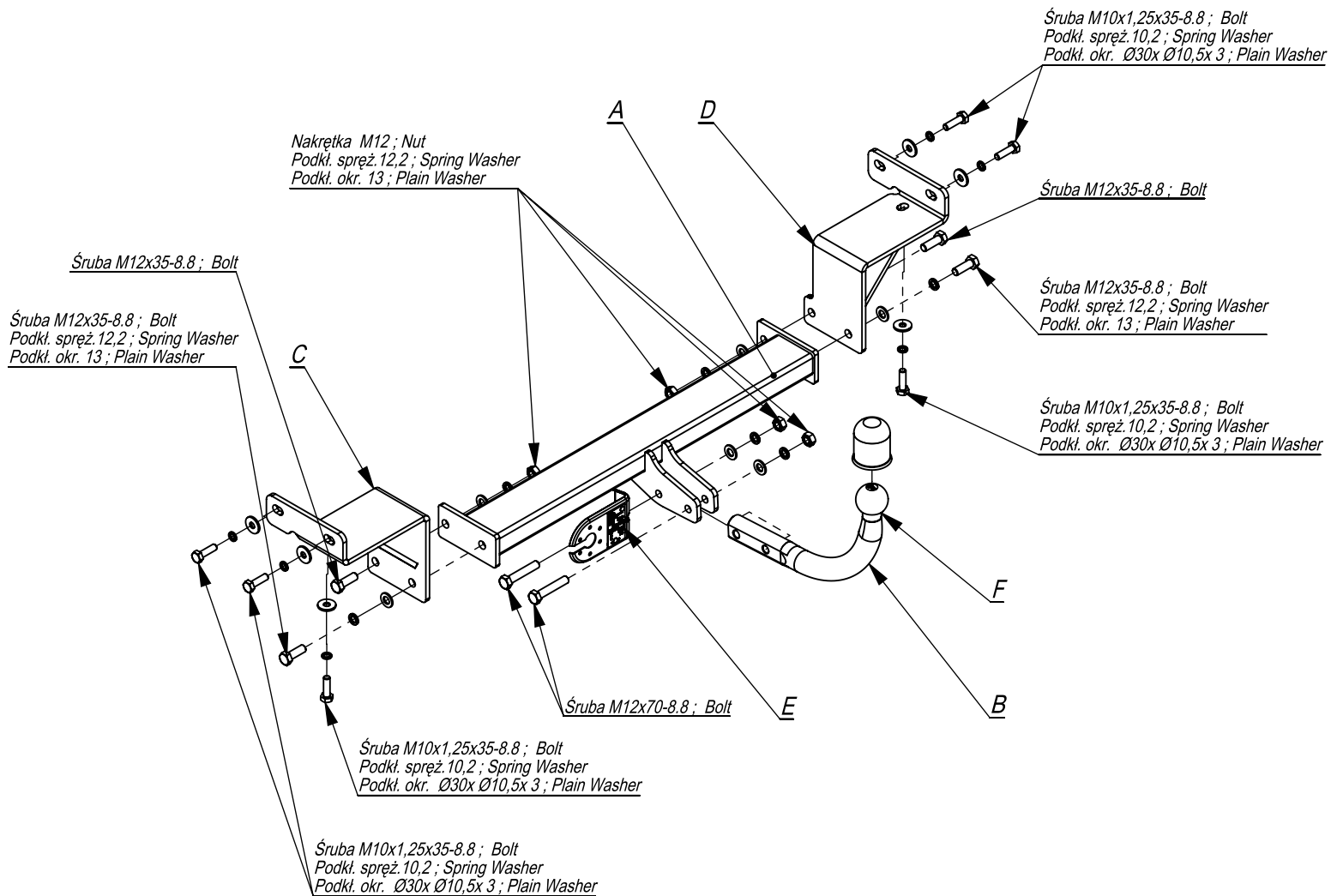

GB The clearance specified in appendix VII, diagram 25a/b of Regulation No. 55.01 UN EU must be guaranteed at laden weight of the vehicle.

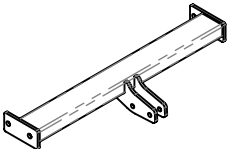
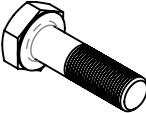
D Der Freiraum nach Anhang VII, Abbildung 25a/b der Vorschriften 55.01 EG ist zu gewährleisten bei zulässigem Gesamtgewicht des Fahrzeuges.

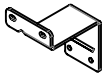
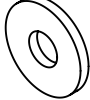
Moment skracający dla śrub i nakrętek (8.8) Torque settings for nuts and bolts (8.8)	
M8	25Nm
M10	55Nm
M12	85Nm
M14	135Nm
M16	195Nm





	A	x1		M12x70	2
				M12x35	4
				M10x1,25x35	6
	B	x1		M12	4
	C	x1		Ø30xØ10,5x3	6
	D	x1		13	6
	E	x1		13	6
	F	x1		10,5	6

Śruba M10x1,25x35-8.8 ; Bolt
 Podkł. spręż. 10,2 ; Spring Washer
 Podkł. okr. Ø30x Ø10,5x 3 ; Plain Washer

Śruba M12x35-8.8 ; Bolt

Śruba M12x35-8.8 ; Bolt
 Podkł. spręż. 12,2 ; Spring Washer
 Podkł. okr. 13 ; Plain Washer

Śruba M10x1,25x35-8.8 ; Bolt
 Podkł. spręż. 10,2 ; Spring Washer
 Podkł. okr. Ø30x Ø10,5x 3 ; Plain Washer

A Pkt. 3 D Pkt. 2 Pkt. 1

Nakrętka M12 ; Nut
 Podkł. spręż. 12,2 ; Spring Washer
 Podkł. okr. 13 ; Plain Washer

C Pkt. 3 Pkt. 1

Śruba M10x1,25x35-8.8 ; Bolt
 Podkł. spręż. 10,2 ; Spring Washer
 Podkł. okr. Ø30x Ø10,5x 3 ; Plain Washer

Śruba M12x35-8.8 ; Bolt
 Podkł. spręż. 12,2 ; Spring Washer
 Podkł. okr. 13 ; Plain Washer

Śruba M12x70-8.8 ; Bolt

Pkt. 2 Śruba M12x35-8.8 ; Bolt

Śruba M10x1,25x35-8.8 ; Bolt
 Podkł. spręż. 10,2 ; Spring Washer
 Podkł. okr. Ø30x Ø10,5x 3 ; Plain Washer

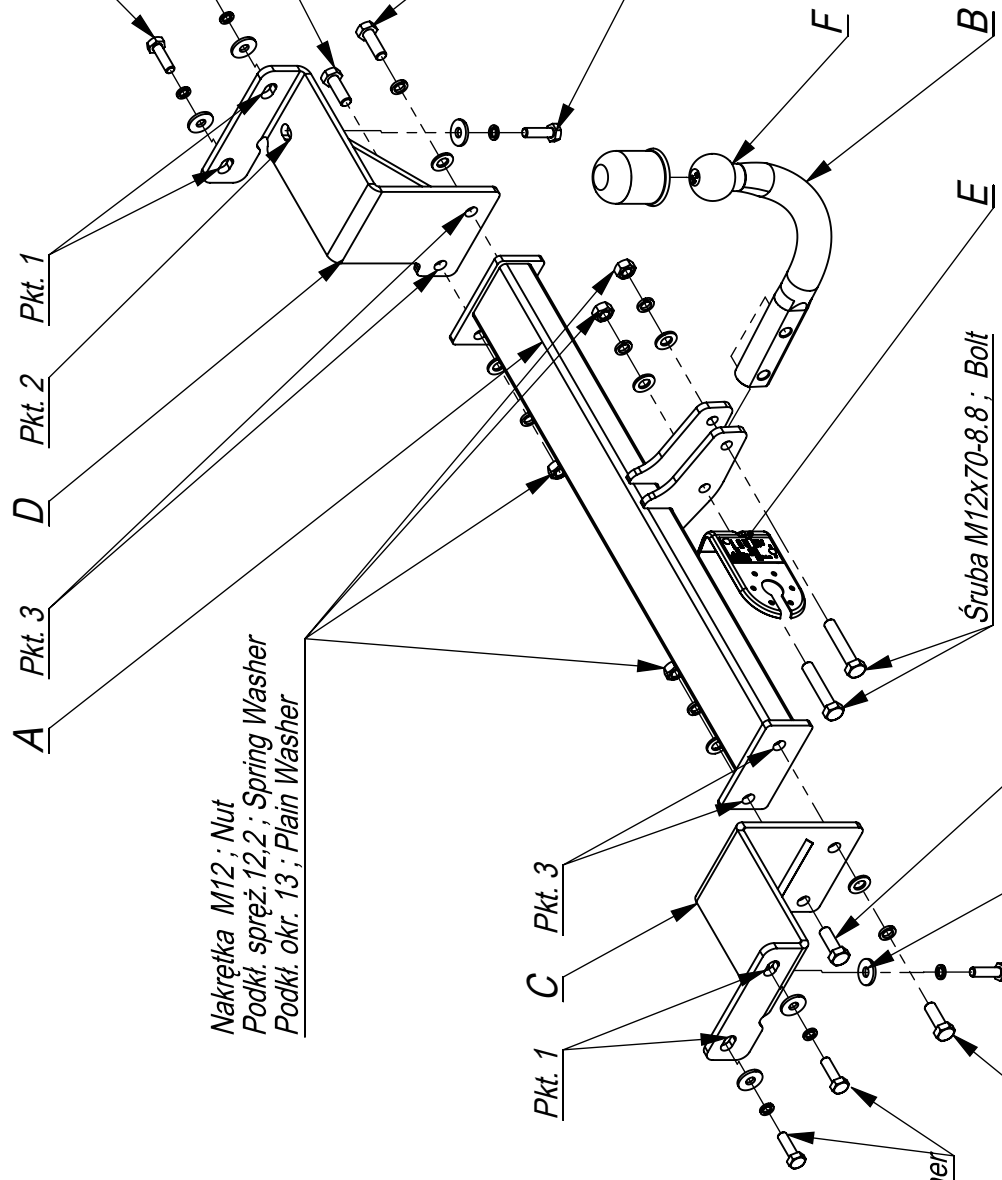

Nr katalogowy Marka

K/023

KIA Ceed combi

od 2007 - >

96-111 Kowiesy, Chojnata 23 A
 tel. +48 46 831 73 31

- Odkręcić plastikowe osłony podłużnic.
- Opuścić tłumik.
- Udzielić technologiczne otwory z gwintami w podłużnicach.
- Przykręcić elementy C i D do podłużnic śrubami M10x35x1,25 wg rys. (pkt 1, 2).
- Do elementów C i D przykręcić belkę zaczepu A śrubami M12x35 8.8 (pkt 3).
- Dokręcić wszystkie śruby z momentem wg tabeli.
- Wykonać wycięcia w plastikowych osłonach podłużnic, a następnie przykręcić je.
- Założyć tłumik.
- Przykręcić kulę i blachę gniazda elektrycznego.
- Podłączyć instalację elektryczną.

- Unscrew the plastic shields of the metal clamps.
- Lower the damper.
- The technological holes with threads in the metal clamps make permeable.
- Screw the elements C and D to the metal clamps with bolts M10x35x1,25, according to the drawing (point 1, 2).
- Screw the main bar A to the elements C and D with bolts M12x35 8.8 (point 3).
- Tighten all the bolts according to the torque setting- see the table.
- Make an openings in the plastic shields of the metal clamps and next screw them.
- Hang the damper.
- Fix the ball and electric plate.
- Connect the electric wires.

