



2008 -

LAND ROVER FREELANDER II

Cat. No. L/031

e20

e20*94/20*0990*00

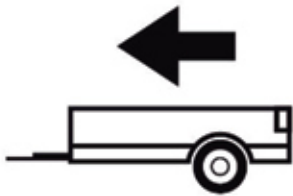

2300Kg



150Kg

D = 11,08kN

D (kN) = $\frac{\text{MAX kg} \times \text{MAX kg}}{\text{MAX kg} + \text{MAX kg}} \times 0,00981$

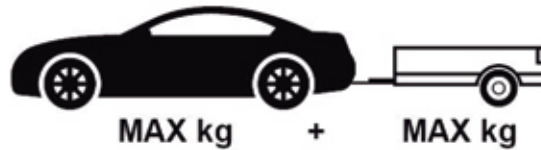

IMIOLA HAK-POL

96-111 KOWIESY, CHOJNATA 23A, POLAND

tel. +48 46 831 73 31, fax +48 831 74 29

e-mail: office@imiola.pl, www.imiola.pl

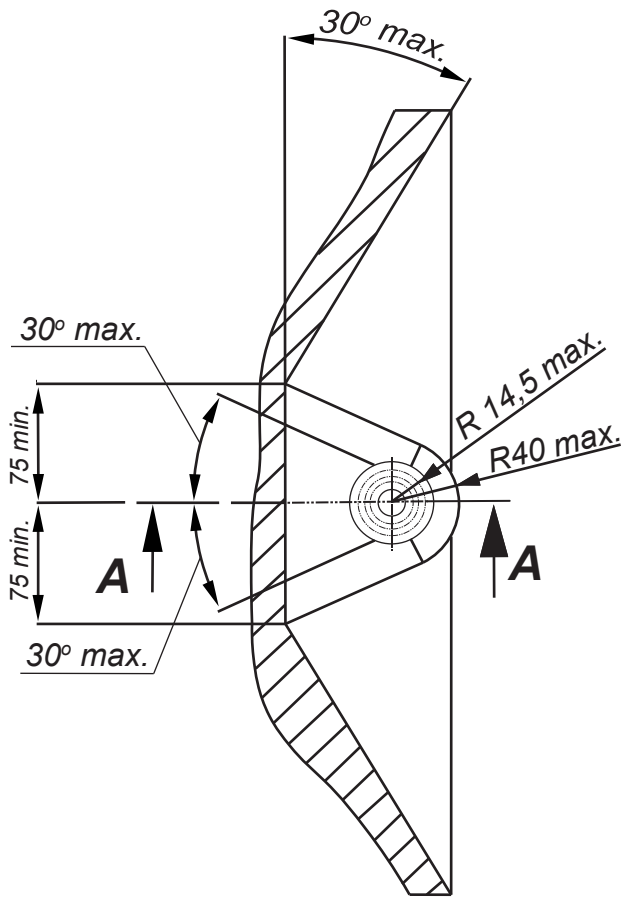

PRZEKRÓJ A-A

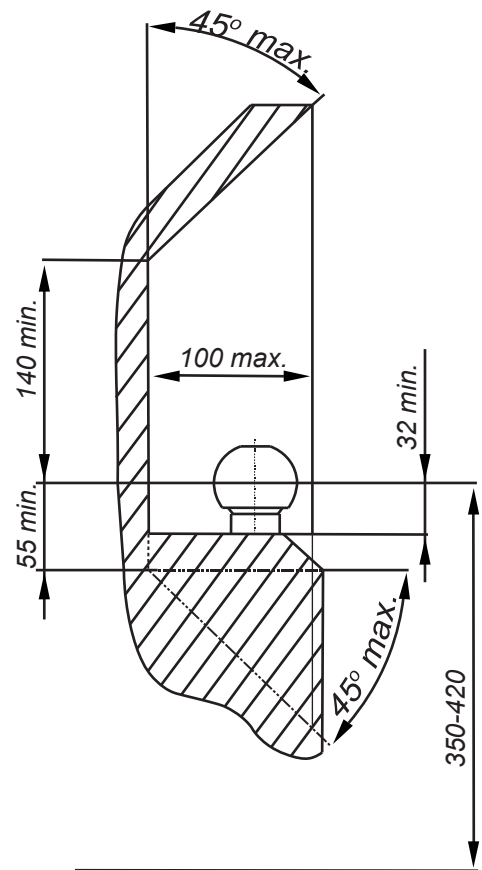

PL Należy zagwarantować przestrzeń swobodną według załącznika VII, rysunek 25a/b Regulaminu EKG ONZ 55.01 przy dopuszczalnym ciężarze całkowitym pojazdu.

F L'espace libre doit être garanti conformément à l'annexe VII, illustration de la réglementation 55.01 CE pour un poids total en charge autorisé du véhicule.

GB The clearance specified in appendix VII, diagram 25a/b of Regulation No. 55.01 UN EU must be guaranteed at laden weight of the vehicle.

D Der Freiraum nach Anhang VII, Abbildung 25a/b der Vorschriften 55.01 EG ist zu gew 25a/bahrleiten bei zulässigem Gesamtgewicht des Fahrzeuges.

Moment skręcający dla śrub i nakrętek (8.8) Torque settings for nuts and bolts (8.8)	
M8	25Nm
M10	55Nm
M12	85Nm
M14	135Nm
M16	195Nm

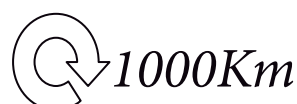

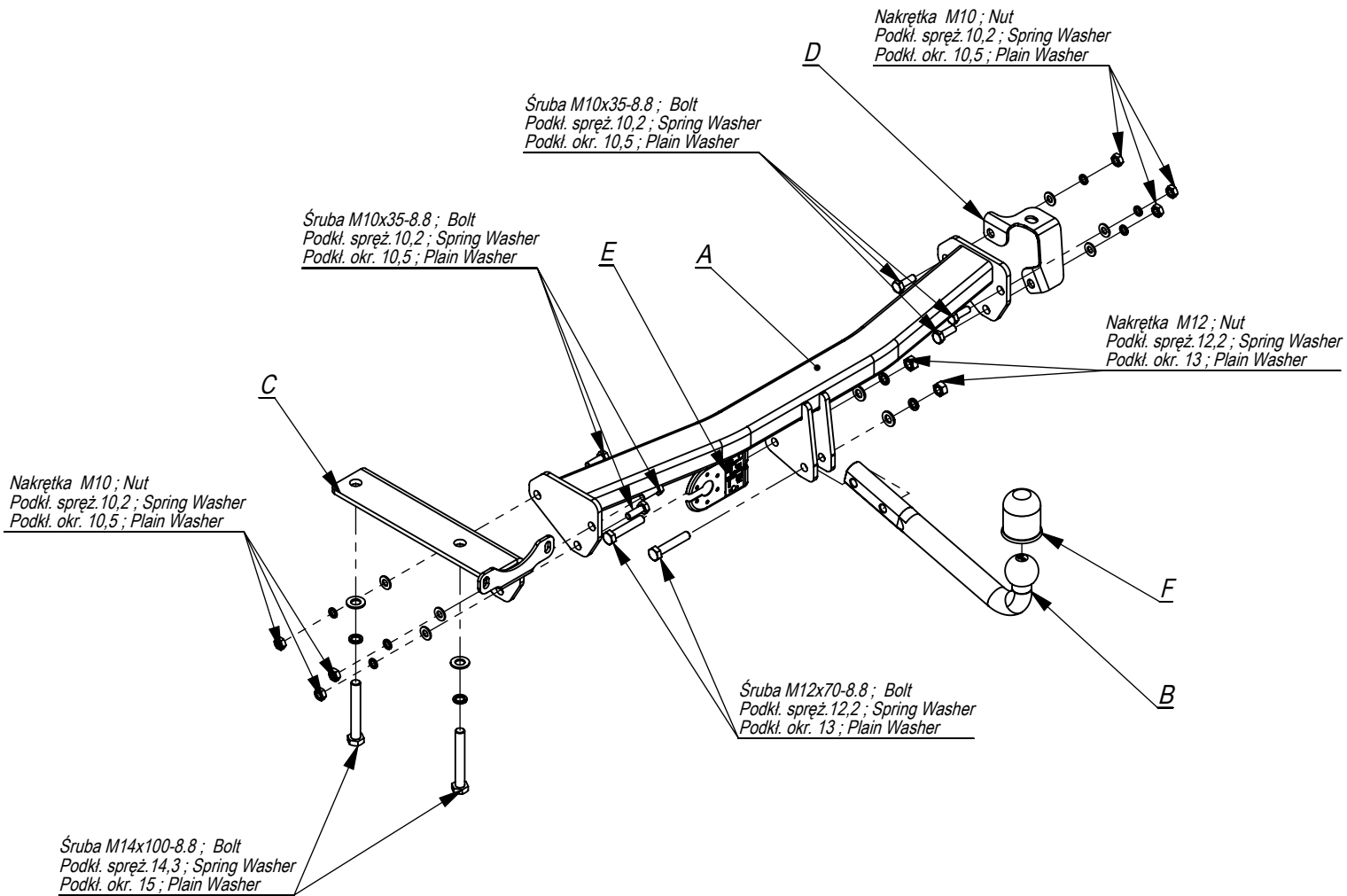

	A	x1		M14x100	2
				M12x70	2
				M10x35	6
	B	x1		M12	2
				M10	6
	C	x1		15	2
				13	2
				10,5	6
	D	x1		12,2	2
	E	x1		14,3	2
	F	x1		10,2	6

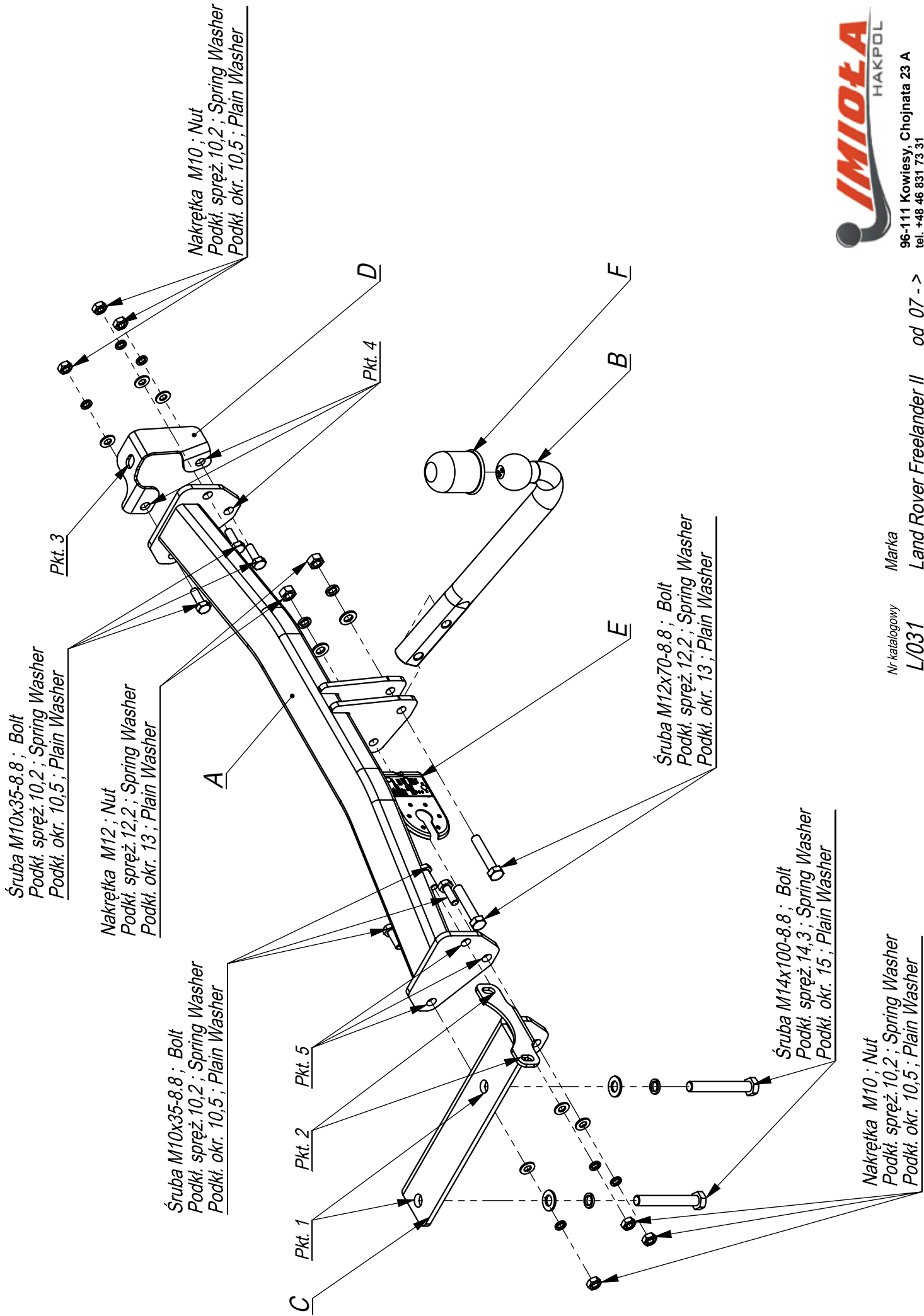

96-111 Kowiesy, Chojnata 23 A
 tel. +48 46 831 73 31

Nr katalogowy
L/031

Marka
Land Rover Freelander II

od 07 ->

- Odkręcić tylny zderzak i lampy.
- Z lewej strony wzmocnienia zderzaka odkręcić nakrętki w części dolnej.
- Na wystające śruby zamontować element haka C (pkt 2) i przykręcić go śrubami M14x100 8.8 (pkt 1).
- Od prawej podłużnicy odkręcić śrubę ucha holowniczego i przykręcić element haka D (pkt 3).
- Belkę haka A przykręcić do elementów C i D śrubami M10x35 8.8 (pkt 4 i 5).
- Przykręcić kulę i blachę gniazda elektrycznego śrubami M12x70 8.8.
- Dokręcić wszystkie śruby z momentem wg tabeli.
- Podłączyć instalację elektryczną.

- Unscrew the rear bumper and lights.
- Unscrew the nuts on the left of the bumper's reinforcement, in the lower part.
- Assemble the element C on the protruding bolts (point 2) and screw with bolts M14x100 8.8 (point 1).
- Unscrew the bolt of the towing eye from the right metal clamp and screw the element D (point 3).
- Screw the main bar A to the elements C and D with bolts M10x35 8.8 (point 4 and 5).
- Fix the ball and electric plate with bolts M12x70 8.8.
- Tighten all the bolts according to the torque setting- see the table.
- Connect the electric wires.

