



# MERCEDES

E-CLASS (S212)  
estate (excl. AMG)

09/2009 -

Cat. No. M/044

**E20** E20 55R-01 4932

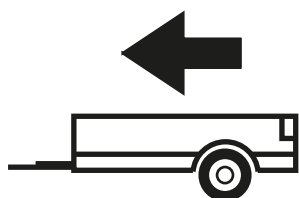

2100kg

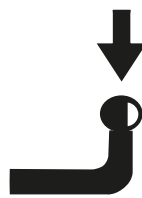

88kg

**D** = 11,64kN

$$D \text{ (kN)} = \frac{\text{MAX kg} \times \text{MAX kg}}{\text{MAX kg} + \text{MAX kg}} \times 0,00981$$

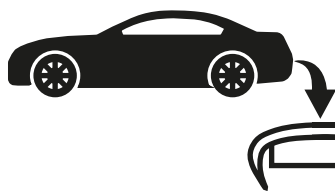

IMIOLA HAK-POL

96-111 KOWIESY, CHOJNATA 23A, POLAND

Tel. + 48 46 831 73 31, fax +48 831 74 29

e-mail: office@imiola.pl, www.imiola.pl

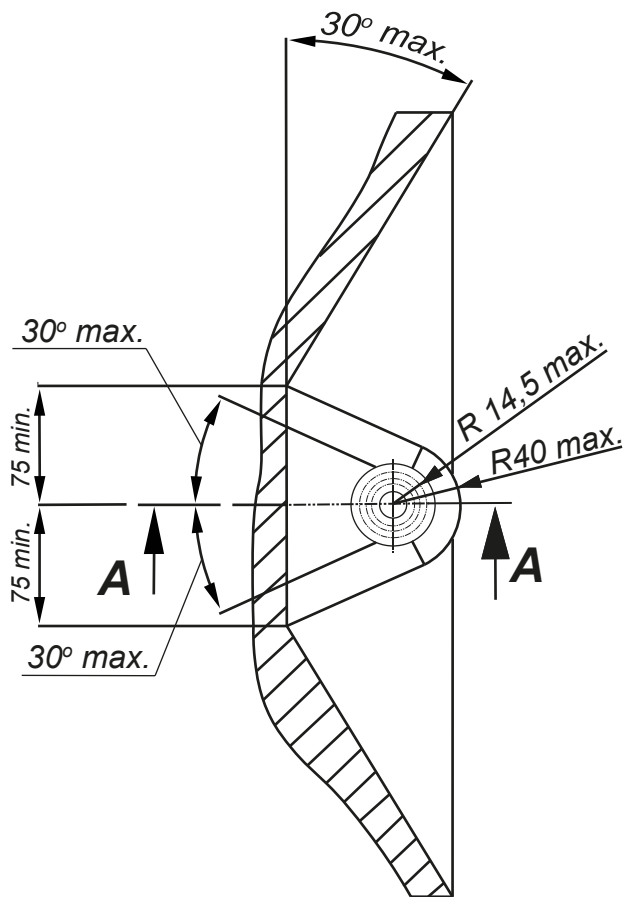

**PRZEKRÓJ A-A**

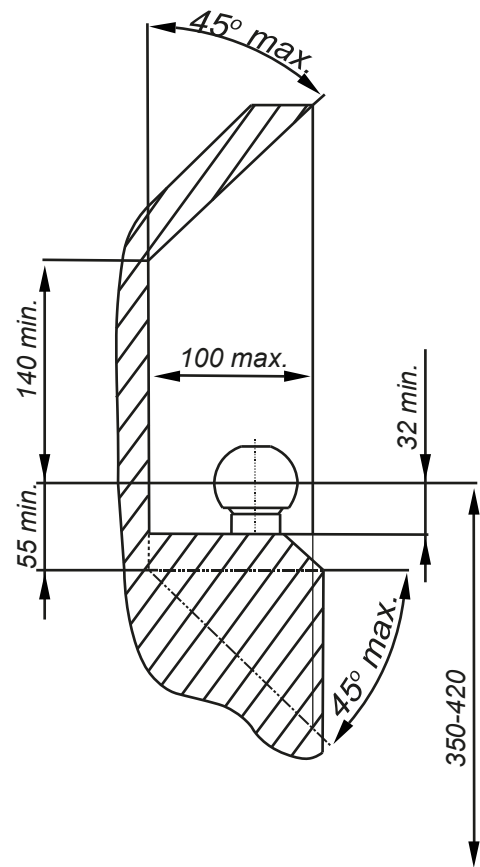

**PL** Należy zagwarantować przestrzeń swobodną według załącznika VII, rysunek 25a/b Regulaminu EKG ONZ 55.01 przy dopuszczalnym ciężarze całkowitym pojazdu.

**F** L'espace libre doit être garanti conformément à l'annexe VII, illustration de la réglementation 55.01 CE pour un poids total en charge autorisé du véhicule.

**GB** The clearance specified in appendix VII, diagram 25a/b of Regulation No. 55.01 UN EU must be guaranteed at laden weight of the vehicle.

**D** Der Freiraum nach Anhang VII, Abbildung 25a/b der Vorschriften 55.01 EG ist zu gew 25a/b abzuwehren bei zulässigem Gesamtgewicht des Fahrzeuges.

<b>Moment skręcący dla śrub i nakrętek (8.8)</b> <b>Torque settings for nuts and bolts (8.8)</b>	
<b>M8</b>	25Nm
M10	55Nm
M12	<b>85Nm</b>
M14	135Nm
M16	195Nm

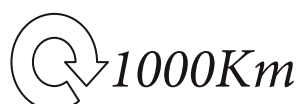

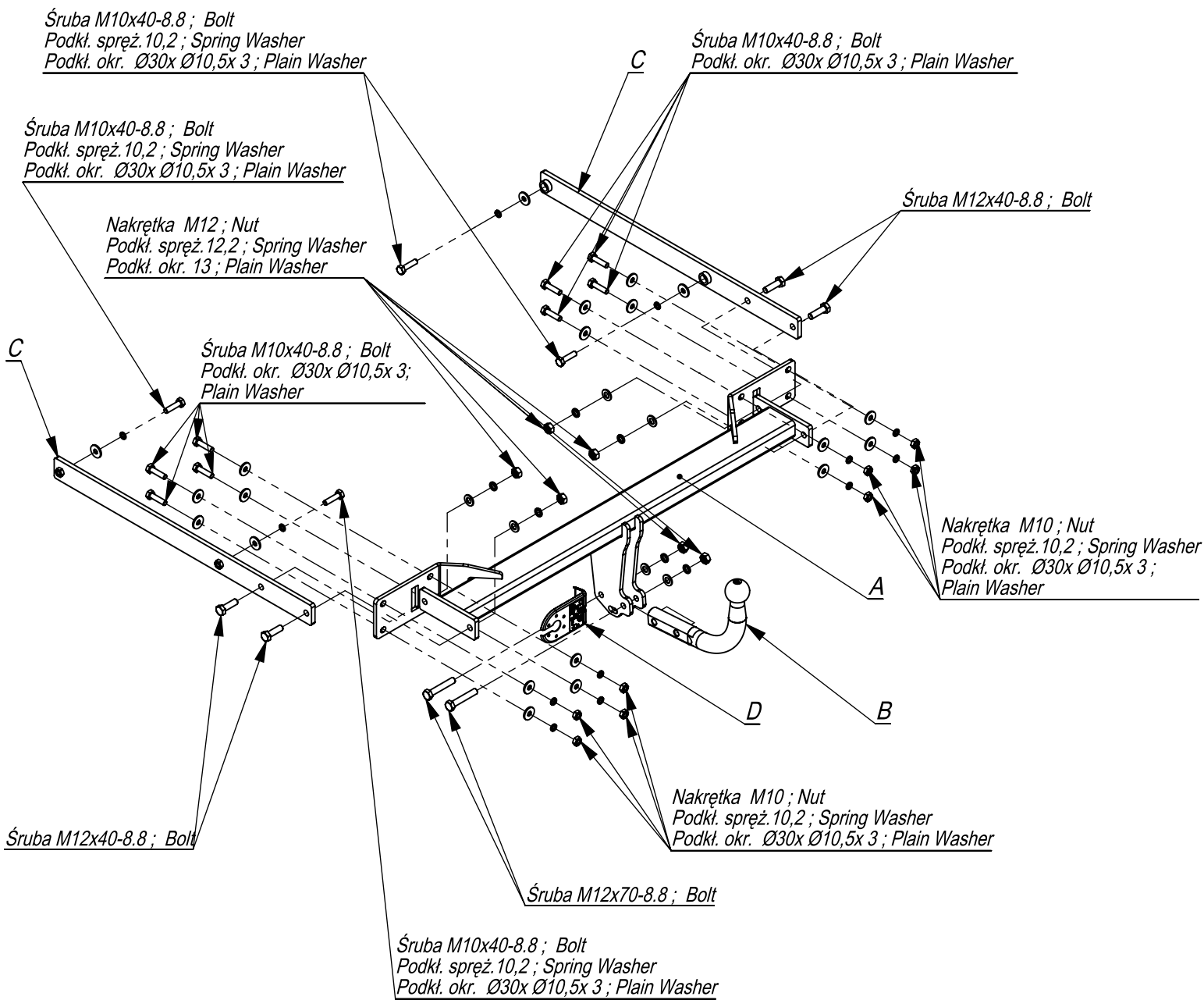

	A	x1		M12x70	2
				M12x40	4
				M10x40	12
	B	x1		M12	6
				M10	8
	C	x2		Ø30xØ10,5x3	20
				13	6
	D	x1		12,2	6
				10,2	12

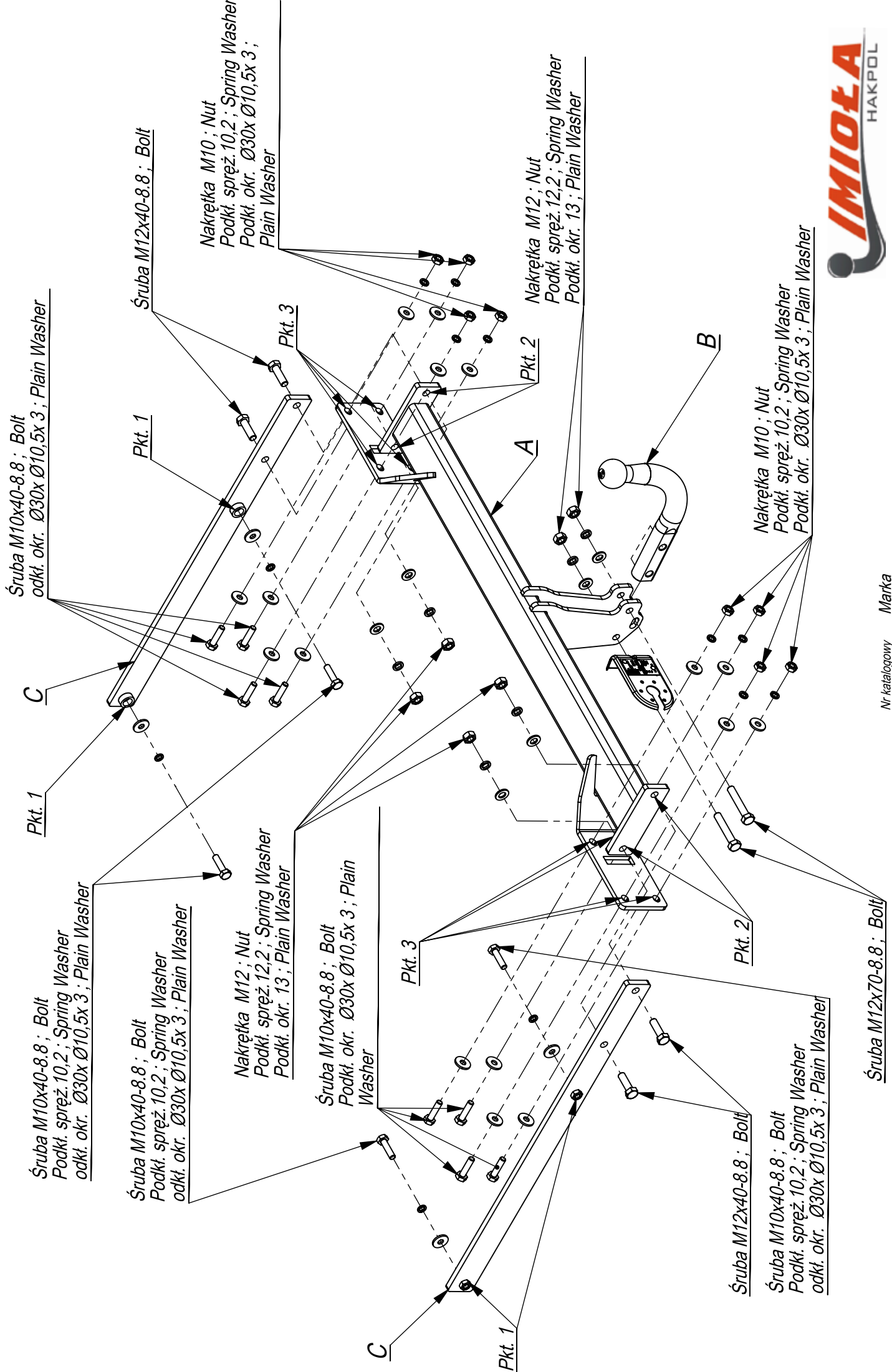

Nr katalogowy  
**M/044**  
 Marka  
**Mercedes E kombi S212** od 09/2009 ->  
 96-111 Kowiesy, Chojnata 23 A  
 tel. +48 46 831 73 31

