



03/2003 - 02-2007

NISSAN X - TRAIL

Cat. No. N/022

e20

e20\*94/20\*0238\*00

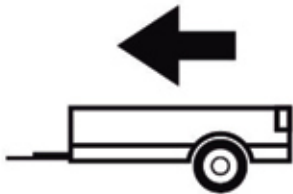

2300Kg



100Kg

**D** = 11,20kN

**D (kN) =**  $\frac{\text{MAX kg} \times \text{MAX kg}}{\text{MAX kg} + \text{MAX kg}} \times 0,00981$

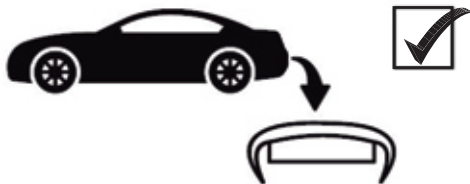

**IMIOLA HAK-POL**

96-111 KOWIESY, CHOJNATA 23A, POLAND

tel. +48 46 831 73 31, fax +48 831 74 29

e-mail: office@imiola.pl, www.imiola.pl

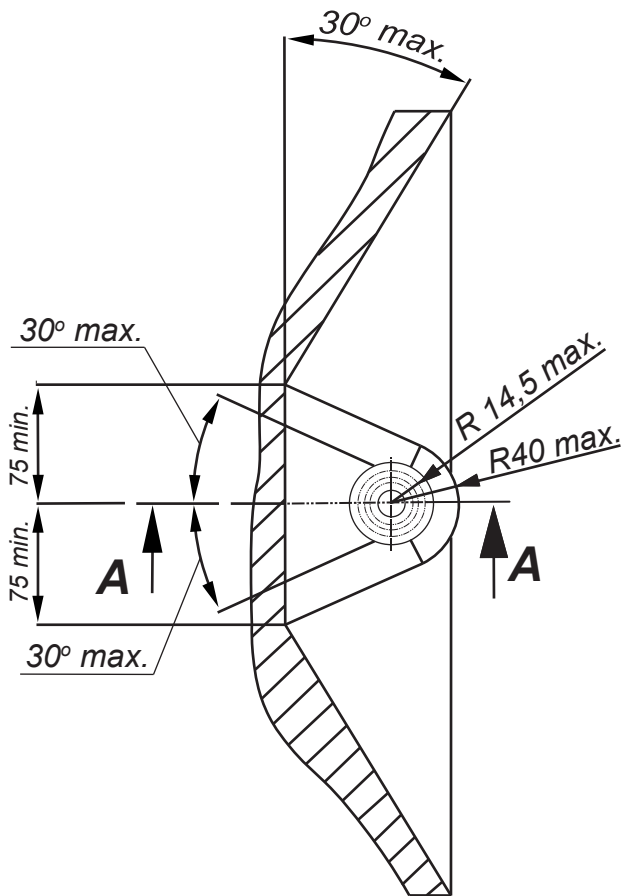

### PRZEKRÓJ A-A

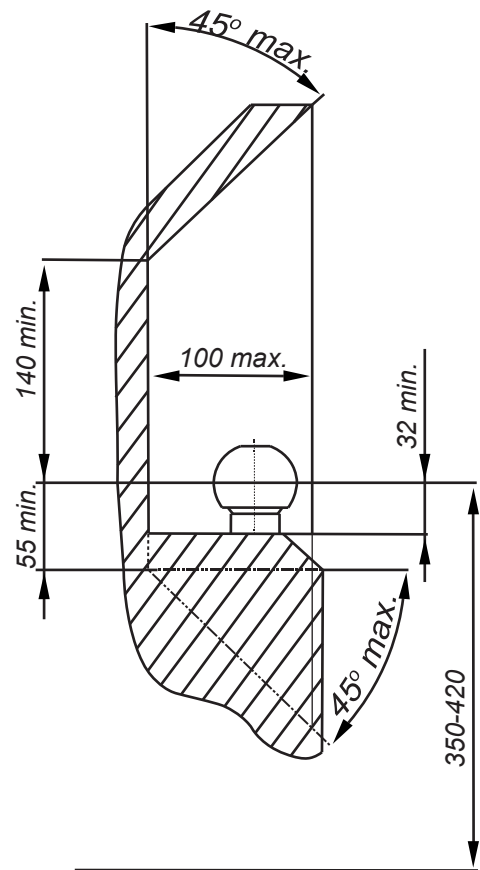

**PL** Należy zagwarantować przestrzeń swobodną według załącznika VII, rysunek 25a/b Regulaminu EKG ONZ 55.01 przy dopuszczalnym ciężarze całkowitym pojazdu.

**F** L'espace libre doit être garanti conformément à l'annexe VII, illustration de la réglementation 55.01 CE pour un poids total en charge autorisé du véhicule.

**GB** The clearance specified in appendix VII, diagram 25a/b of Regulation No. 55.01 UN EU must be guaranteed at laden weight of the vehicle.

**D** Der Freiraum nach Anhang VII, Abbildung 25a/b der Vorschriften 55.01 EG ist zu gew 25a/b abzuhalten bei zulässigem Gesamtgewicht des Fahrzeuges.

Moment skręcący dla śrub i nakrętek (8.8) Torque settings for nuts and bolts (8.8)	
M8	25Nm
M10	55Nm
M12	85Nm
M14	135Nm
M16	195Nm

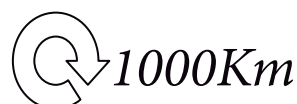

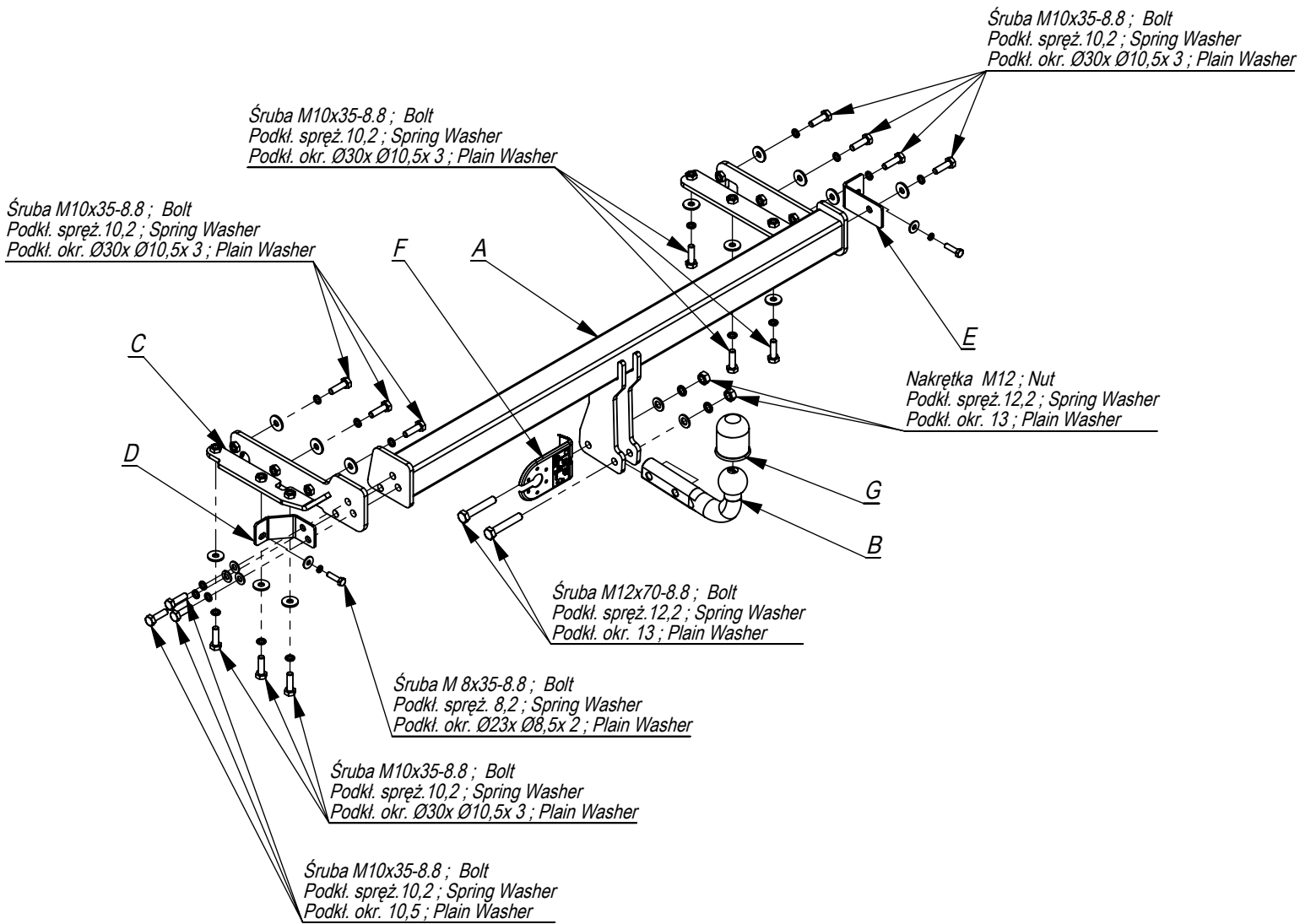

	A	x1		M12x70	2
				M10x35	16
				M8x25	2
	B	x1		M12	2
	C	x1		Ø30xØ10,5x3	13
				Ø23xØ8,5x2	2
	D	x1		13	2
				10,5	3
	E	x1		12,2	2
				10,2	16
				8,2	2
	F	x1			
	G	x1			

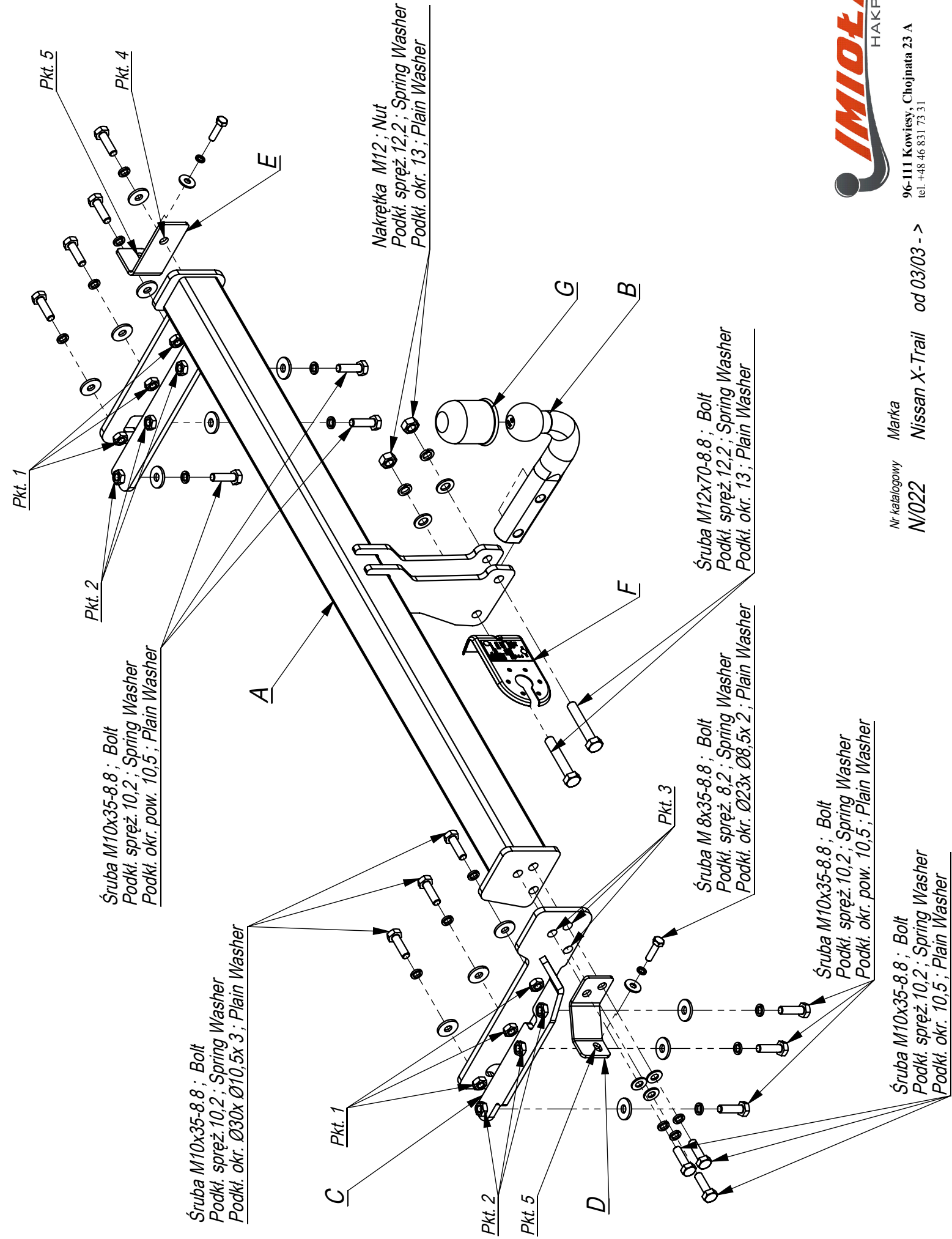

- Odkręcić zderzak.
- Od tylnego pasa odkręcić zaślepki podłużnic oraz osłonę termiczną (nie będzie już montowana).
- W lewą podłużnicę wsunąć element haka C i poprzez technologiczne otwory przykręcić lekko śrubami M10x35 8.8 (pkt 1 i 2).
- W prawą podłużnicę wsunąć belkę zaczepu A i przykręcić lekko śrubami M10x35 8.8 (pkt 1 i 2).
- Do belki haka A przykręcić element haka C śrubami M10x35 8.8 (pkt 3).
- Elementy D i E przykręcić do zaczepu śrubami M10x35 8.8 (pkt 4) i do samochodu śrubami M8x30 8.8 (pkt 5).
- Dokręcić wszystkie śruby z momentem wg tabeli.
- Wykonać wycięcie w zderzaku na uchwyty kuli.
- Przykręcić zderzak.
- Przykręcić kulę i blachę gniazda elektrycznego śrubami M12x70 8.8.
- Podłączyć instalację elektryczną.

- Unscrew the bumper.
- Unscrew the plugs of the metal clamps and thermal shield (it will not be used any more) from the rear belt of the car.
- Insert the element C in the left metal clamp and screw slightly, through the technological holes, with bolts M10x35 8.8 (point 1 and 2).
- Insert the main bar A in the right metal clamp and screw slightly, through the technological holes, with bolts M10x35 8.8 (point 1 and 2).
- Screw the element C to the main bar A with bolts M10x35 8.8 (point 3).
- Screw the elements D and E to the tow bar with bolts M12x35 8.8 (point 4) and to the car with bolts M8x30 8.8 (point 5).
- Tighten all the bolts according to the torque settings-see the table.
- Cut out the fragment of the bumper to place the handles of the ball.
- Screw the bumper.
- Fix the ball and electric plate with bolts M12x70 8.8.
- Connect the electric wires.

- Serrer le pare-chocs.
- Dévisser les bouchons de longerons de la partie arrière et la protection thermique (ne sera plus monté).
- Introduire les éléments C de crochet dans le longeron gauche et ensuite visser légèrement par les boulons M10x35 8.8 (point 1 et 2) à travers les ouvertures.
- Insérer la traverse d'attache A dans le longeron droit et serrer légèrement par les boulons M10x35 8.8 (point 1 et 2).
- Visser l'élément C à la traverse de crochet A par les boulons M10x35 8.8 (point 3).
- Visser les éléments D et E à l'attache par les boulons M10x35 8.8 (point 4) et à la voiture par les boulons M8x30 8.8 (point 5).
- Serrer tous les boulons avec un couple de serrage selon tableau.
- Entreouvrir le pare-chocs pour fixer les attaches de la boule.
- Fixer un pare-chocs.
- Visser la boule et tôle de la prise électrique par les boulons M12x70 8.8.
- Raccorder le circuit électrique

