



VOLKSWAGEN T-5

01/2003 -

Cat. No. **W/023**

e20

e20*94/20*0134*00

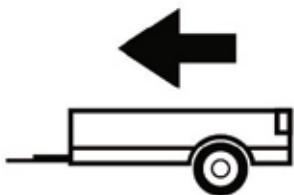

2800 Kg



120 Kg

D = 14,18 kN

D (kN) =



MAX kg

x

MAX kg

x 0,00981



MAX kg

+

MAX kg



IMIOLA HAK-POL

96-111 KOWIESY, CHOJNATA 23A, POLAND

tel. +48 46 831 73 31, fax +48 831 74 29

e-mail: office@imiola.pl, www.imiola.pl

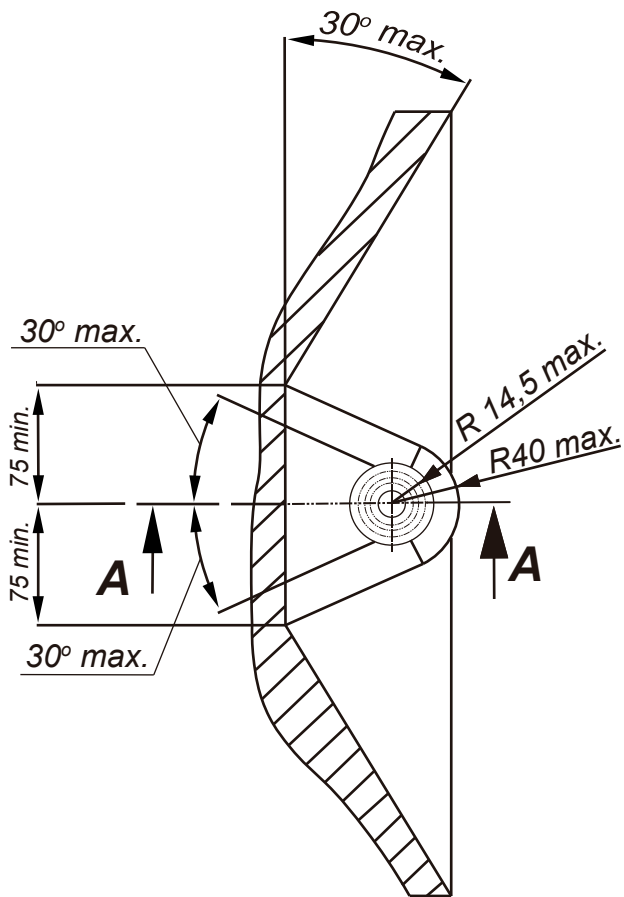

PRZEKRÓJ A-A

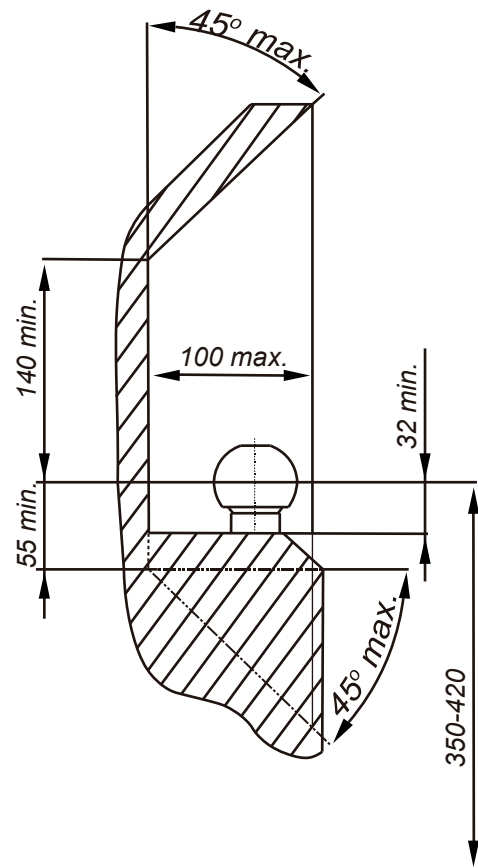

PL Należy zagwarantować przestrzeń swobodną według załącznika VII, rysunek 25a/b Regulaminu EKG ONZ 55.01 przy dopuszczalnym ciężarze całkowitym pojazdu.

F L'espace libre doit être garanti conformément à l'annexe VII, illustration de la réglementation 55.01 CE pour un poids total en charge autorisé du véhicule.

GB The clearance specified in appendix VII, diagram 25a/b of Regulation No. 55.01 UN EU must be guaranteed at laden weight of the vehicle.

D Der Freiraum nach Anhang VII, Abbildung 25a/b der Vorschriften 55.01 EG ist zu gewährleisten bei zulässigem Gesamtgewicht des Fahrzeuges.

Moment skręcący dla śrub i nakrętek (8.8) Torgue settings for nuts and bolts (8.8)	
M8	25Nm
M10	55Nm
M12	85Nm
M14	135Nm
M16	195Nm

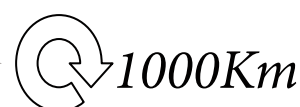

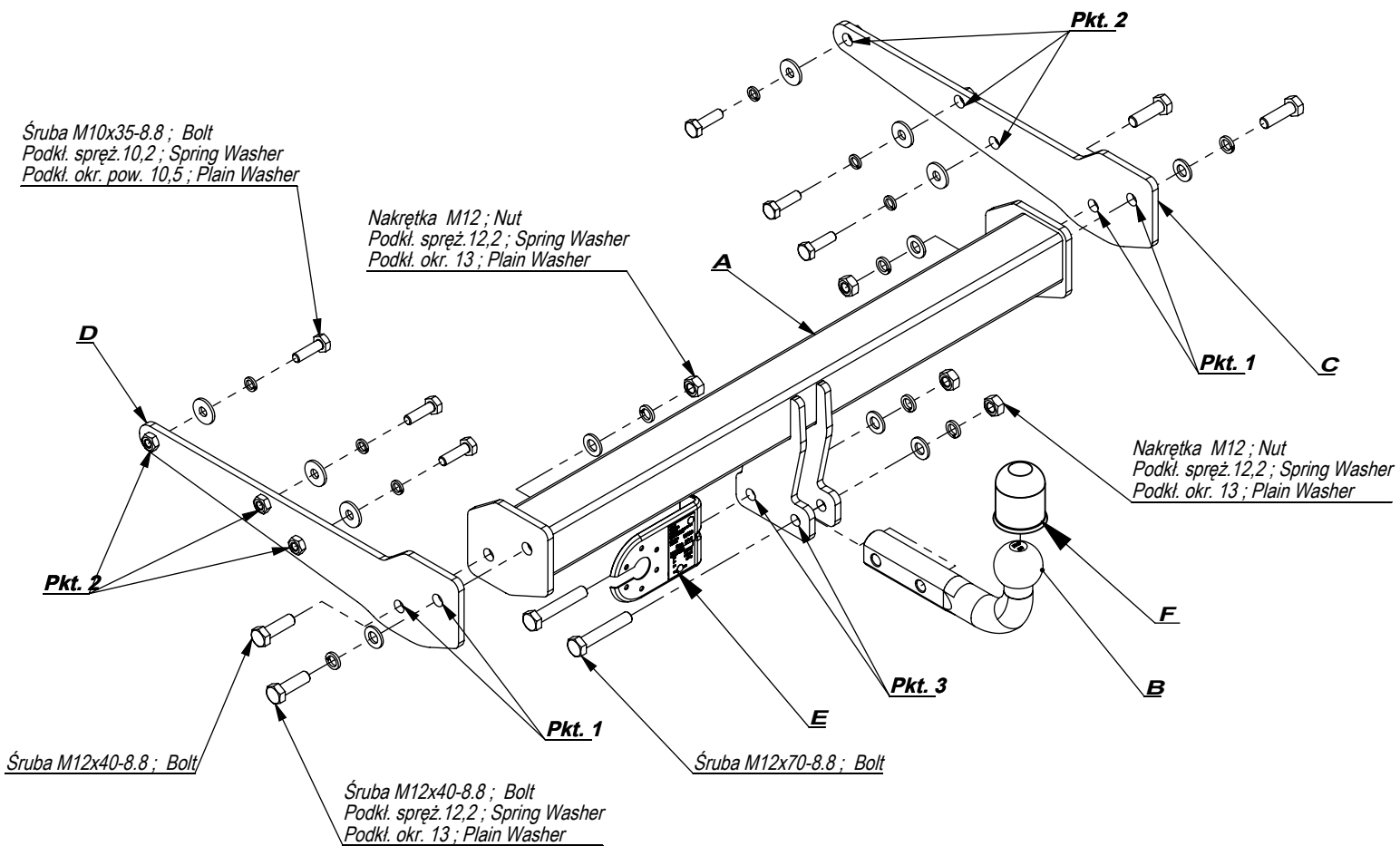

	A	x1		M12x70	2
				M12x40	4
				M10x35	6
	B	x1		M12	4
	C	x1		13	6
	D	x1		12,2	6
				10,2	6
	E	x1		Ø30xØ10,5x3	6
	F	x1			

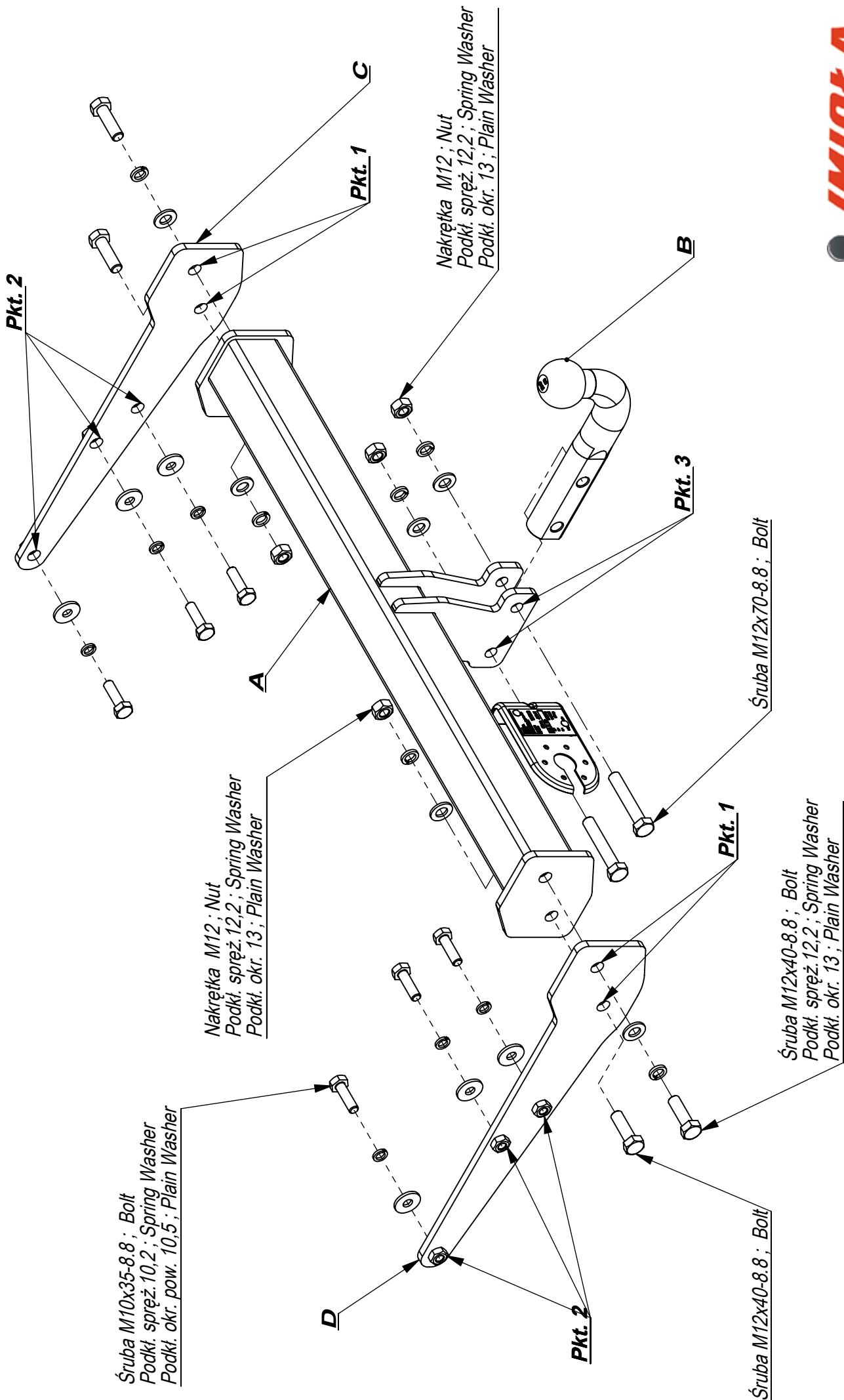

Śruba M10x35-8.8 ; Bolt
 Podkł. spręż. 10,2 ; Spring Washer
 Podkł. okr. pow. 10,5 ; Plain Washer

Nakrętka M12 ; Nut
 Podkł. spręż. 12,2 ; Spring Washer
 Podkł. okr. 13 ; Plain Washer

Nakrętka M12 ; Nut
 Podkł. spręż. 12,2 ; Spring Washer
 Podkł. okr. 13 ; Plain Washer

Śruba M12x40-8.8 ; Bolt

Śruba M12x40-8.8 ; Bolt
 Podkł. spręż. 12,2 ; Spring Washer
 Podkł. okr. 13 ; Plain Washer

Śruba M12x70-8.8 ; Bolt



Nr katalogowy
W/023

Marka
Volkswagen Transporter T501/2003

96-111 Kowiesy, Chojnata 23 A
 Tel. +48 46 831 73 31

- Odkręcić koło zapasowe, zderzak, belkę zderzeniową (nie będzie już wykorzystana) oraz ucho holownicze.
- Wsporniki zaczepu C i D włożyć w podłużnice i w technologicznych otworach lekko przykręcić śrubami M10x35 8.8 (pkt 2).
- Przykręcić lekko belkę zaczepu A do wsporników C i D śrubami M12x40 8.8 (pkt 1).
- Dokręcić wszystkie śruby z momentem wg tabeli.
- Podłączyć instalację elektryczną.
- Zamontować zderzak, przykręcić koło zapasowe.
- Przykręcić kulę zaczepu i blachę gniazda elektrycznego.

- Unscrew the spare wheel, bumper, bumper bar (it will not be used any more) and towing eye.
- Place supporters C and D in the metal clamps and screw slightly in the technological holes with bolts M10x35 8.8 (point 2).
- Screw slightly the main bar A to the supporters C and D with bolts M12x40 8.8 (point 1).
- Tighten all the bolts according to the torque setting- see the table.
- Connect the electric wires.
- Assemble the bumper and screw the spare wheel.
- Fix the ball and electric plate.

- Déposer le pare-choc, traverse (ne sera plus utilisée) et l'oreille d'attelage.
- Insérer les console d'attache C et D dans les longerons, serrer légèrement avec les boulons M10x35 8.8 (point 2).
- Visser légèrement la traverse d'attache A aux consoles C et D par les boulons M12x40 8.8 (point 1).
- Serrer tous les boulons avec un couple de serrage selon tableau.
- Raccorder le circuit électrique.
- Reposer le pare-choc, fixer la roue de secours.
- Visser la boule d'attelage et le socle de prise électrique.

