



06/2005 - 01/2011

## VOLKSWAGEN JETTA

Cat. No. W/030

e20

e20\*94/20\*1007\*00

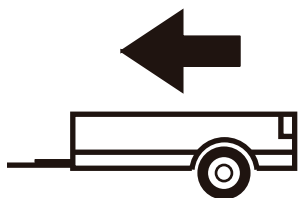

1742Kg

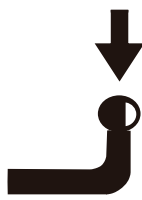

75Kg

**D** = 9,20kN

**D (kN) =**



MAX kg

x

MAX kg

x 0,00981



MAX kg

+

MAX kg

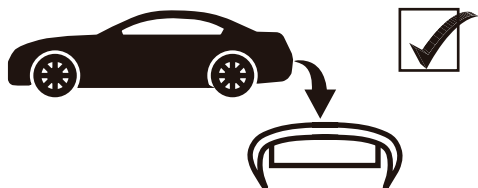

**IMIOLA HAK-POL**

96-111 KOWIESY, CHOJNATA 23A, POLAND

tel. +48 46 831 73 31, fax +48 831 74 29

e-mail: office@imiola.pl, www.imiola.pl

## PRZEKRÓJ A-A

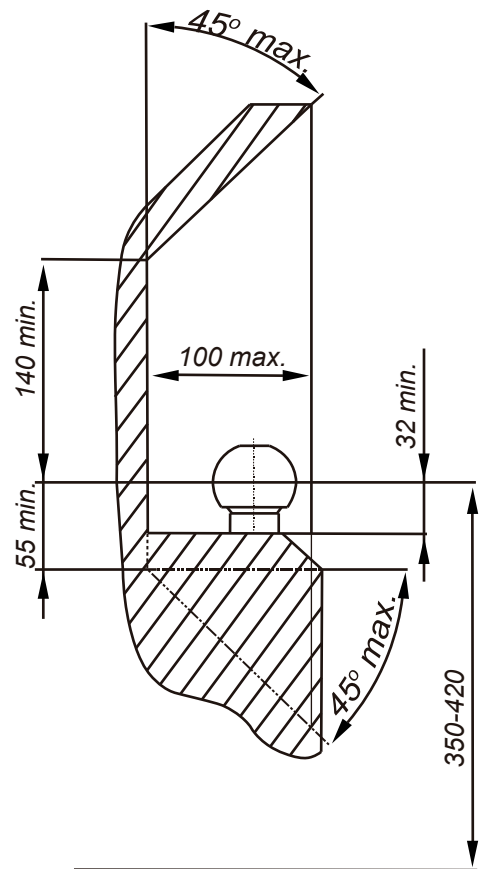
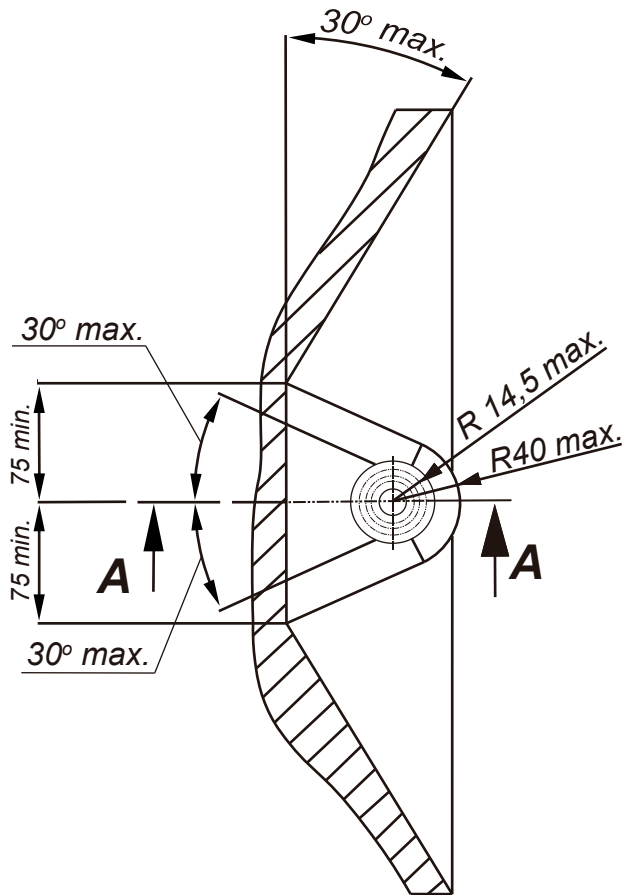

**PL** Należy zagwarantować przestrzeń swobodną według załącznika VII, rysunek 25a/b Regulaminu EKG ONZ 55.01 przy dopuszczalnym ciężarze całkowitym pojazdu.

**F** L'espace libre doit être garanti conformément à l'annexe VII, illustration de la réglementation 55.01 CE pour un poids total en charge autorisé du véhicule.







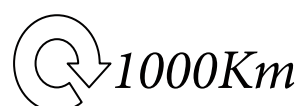

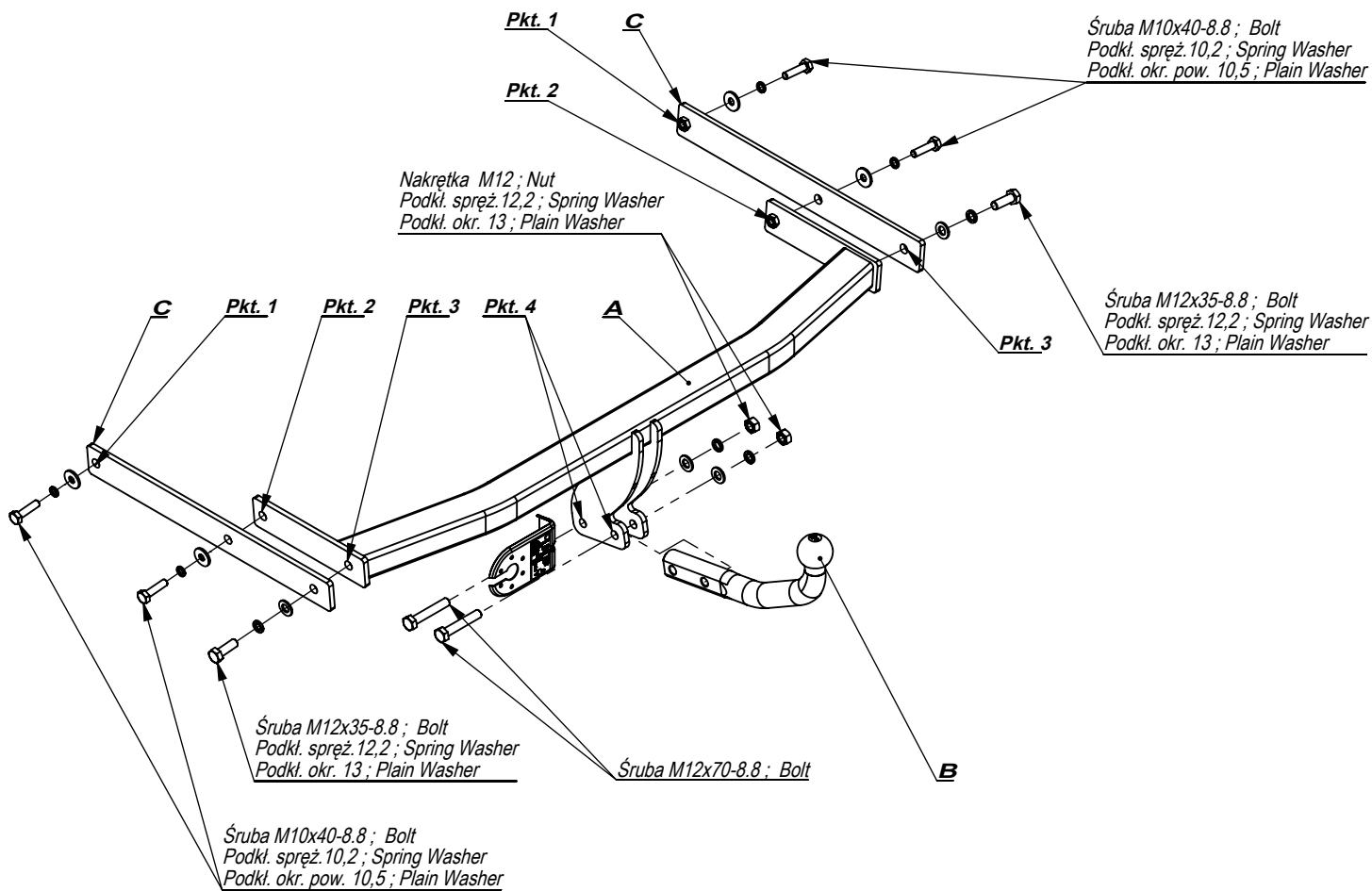

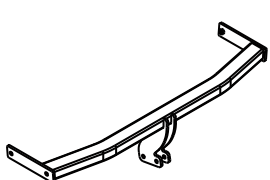
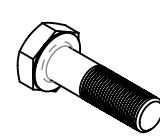
**GB** The clearance specified in appendix VII, diagram 25a/b of Regulation No. 55.01 UN EU must be guaranteed at laden weight of the vehicle.

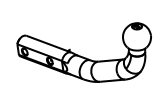
**D** Der Freiraum nach Anhang VII, Abbildung 25a/b der Vorschriften 55.01 EG ist zu gew 25a/b abzu gewährleisten bei zulässigem Gesamtgewicht des Fahrzeuges.

Moment skręcający dla śrub i nakrętek (8.8) Torgue settings for nuts and bolts (8.8)	
M8	25Nm
M10	55Nm
M12	85Nm
M14	135Nm
M16	195Nm





	A	x1		M12x70	2
				M12x35	2
					M10x40
	B	x1		M12	2
	C	x2		13	4
	D	x1		12,2	4
				10,2	4
	E	x1		Ø30xØ10,5x3	4

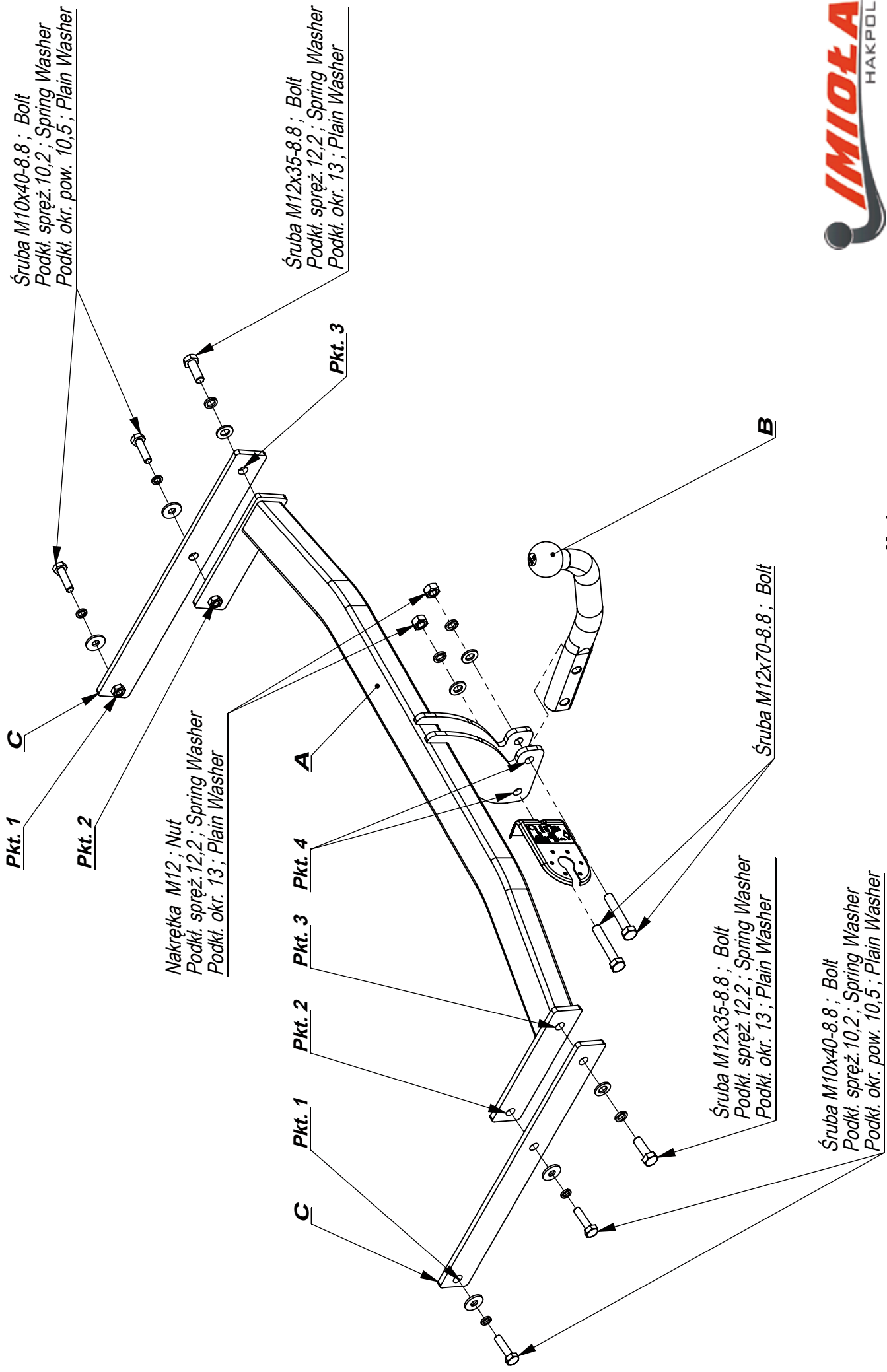

Nr katalogowy

Marka

**W/030**

**Volkswagen Jetta0d 06/05 - >**

96-111 Kowiesy, Chojnata 23 A  
tel. +48 46 831 73 31

- Odkręcić zderzak oraz wzmocnienie zderzaka (nie będzie już wykorzystane).
- Odkręcić osłonę termiczną nad tłumikiem.
- Elementy haka C wsunąć do podłużnic i poprzez technologiczne otwory skręcić śrubami M10x40 8.8 (pkt 1).
- Do elementów C przykręcić lekko belkę zaczepu A (pkt 2) śrubami M10x40 8.8 oraz śrubami M12x35 8.8 (pkt 3).
- Dokręcić śruby z momentem wg tabeli.
- Podłączyć instalację elektryczną.
- Wyciąć w zderzaku miejsce na łapki kuli.
- Zamontować zderzak.
- Przykręcić kulę i blachę gniazda elektrycznego śrubami M12x70 8.8.

- Unscrew the bumper and reinforcement of the bumper (it will not be used any more).
- Unscrew the thermal shield over the damper.
- Insert elements C in the metal clamps and screw through the technological holes with bolts M10x40 8.8 (point 1).
- Screw slightly the main bar A to the elements C (point 2) with bolts M10x40 8.8 and M12x35 8.8 (point 3).
- Tighten all the bolts according to the torque setting- see the table.
- Connect the electric wires.
- Cut out the fragment in the bumper to place the handles of the ball.
- Assemble the bumper.
- Fix the ball and electric plate with bolts M12x70 8.8.

