



MAZDA 3 sed.

2004 - 2009

(sport appearance pack)

Cat. No. X/010

EKG/ONZ: 10/09

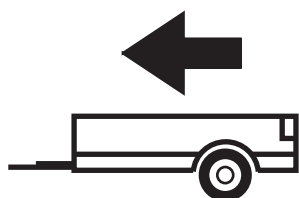

1765Kg

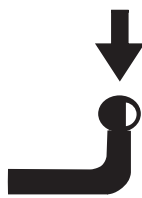

75Kg

**D** = 8,70kN

**D (kN) =**



MAX kg

x

MAX kg

x 0,00981



MAX kg

+

MAX kg



**IMIOLA HAK-POL**

96-111 KOWIESY, CHOJNATA 23A, POLAND

tel. +48 46 831 73 31, fax +48 831 74 29

e-mail: office@imiola.pl, www.imiola.pl

## PRZEKRÓJ A-A

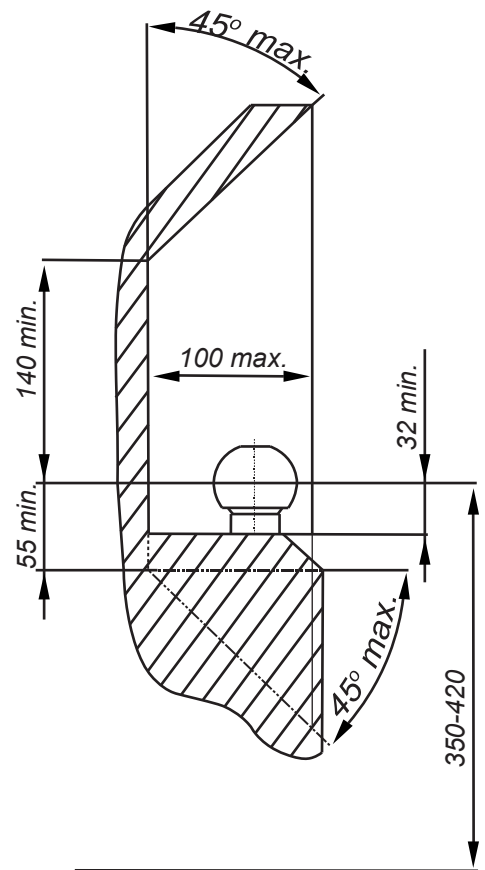
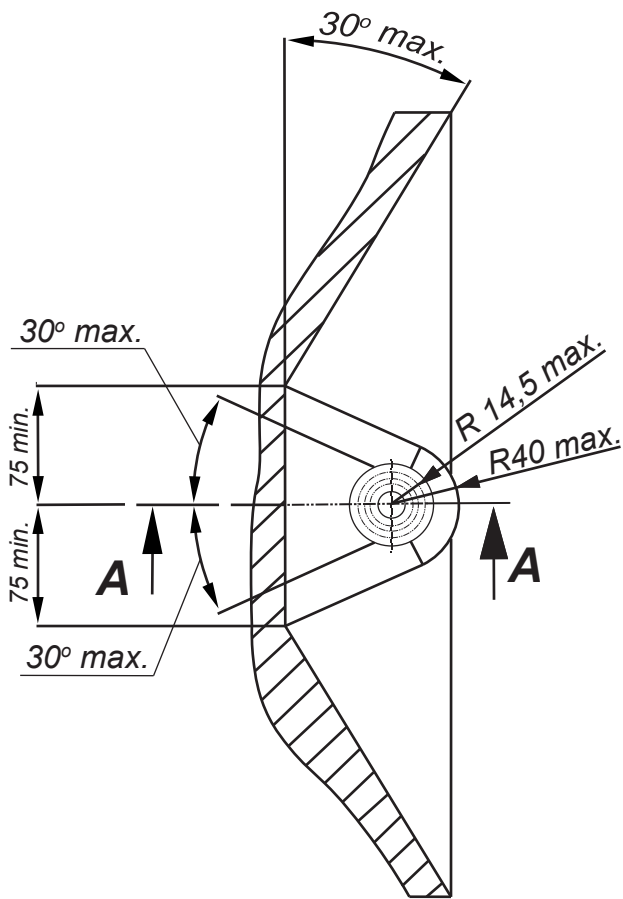

**PL** Należy zagwarantować przestrzeń swobodną według załącznika VII, rysunek 25a/b Regulaminu EKG ONZ 55.01 przy dopuszczalnym ciężarze całkowitym pojazdu.

**GB** The clearance specified in appendix VII, diagram 25a/b of Regulation No. 55.01 UN EU must be guaranteed at laden weight of the vehicle.

**F** L'espace libre doit être garanti conformément à l'annexe VII, illustration de la réglementation 55.01 CE pour un poids total en charge autorisé du véhicule.

**D** Der Freiraum nach Anhang VII, Abbildung 25a/b der Vorschriften 55.01 EG ist zu gew 25a/bahrleiten bei zulässigem Gesamtgewicht des Fahrzeuges.

Moment skręcący dla śrub i nakrętek (8.8) Torque settings for nuts and bolts (8.8)	
M8	25Nm
M10	55Nm
M12	85Nm
M14	135Nm
M16	195Nm

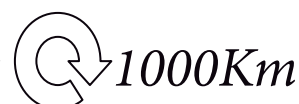

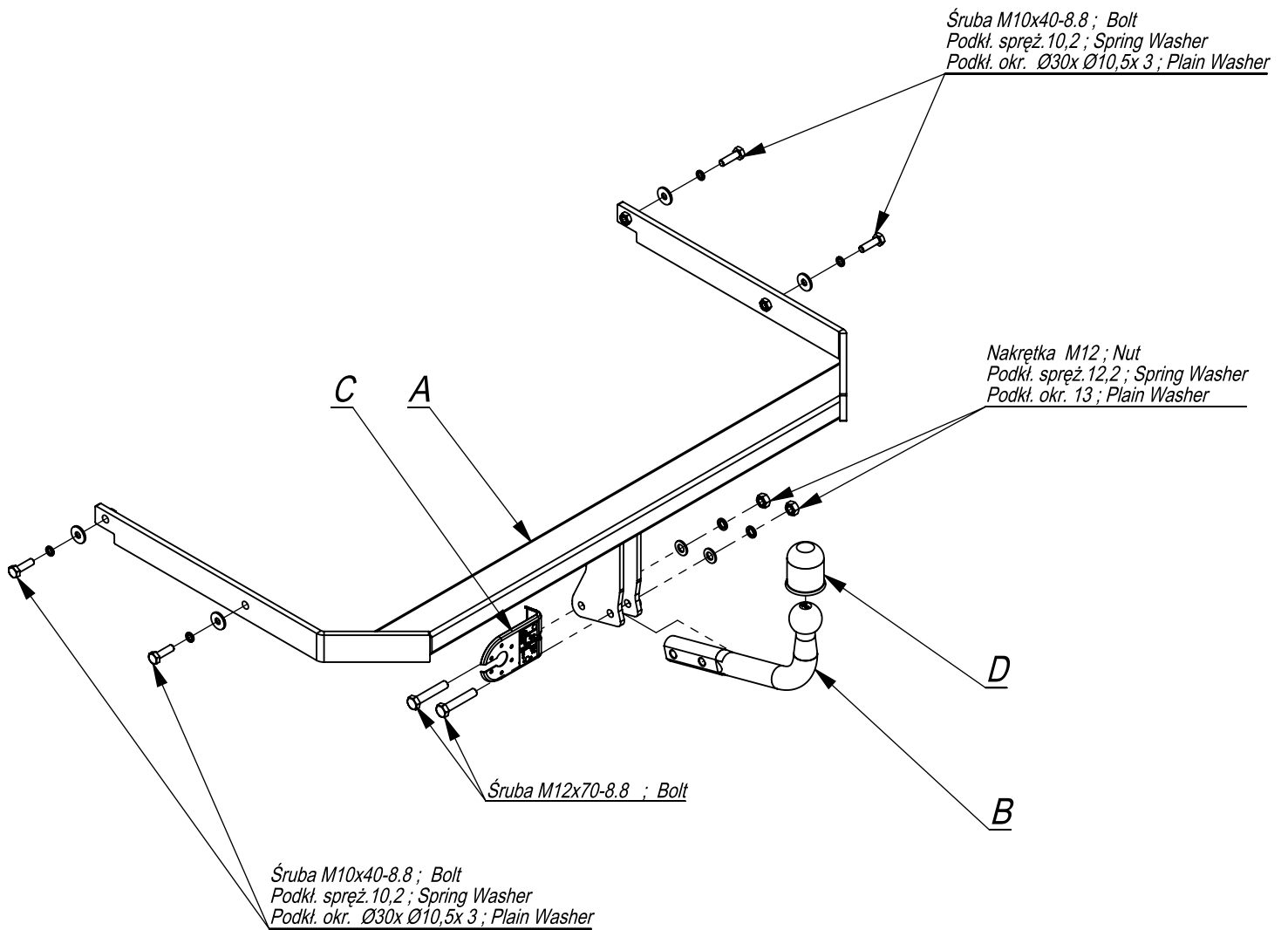

	A	x1		M12x70	2
				M10x40	4
	B	x1		M12	2
	C	x1		Ø30xØ10,5x3	4
	D	x1		13	2
				12,2	2
				10,2	4

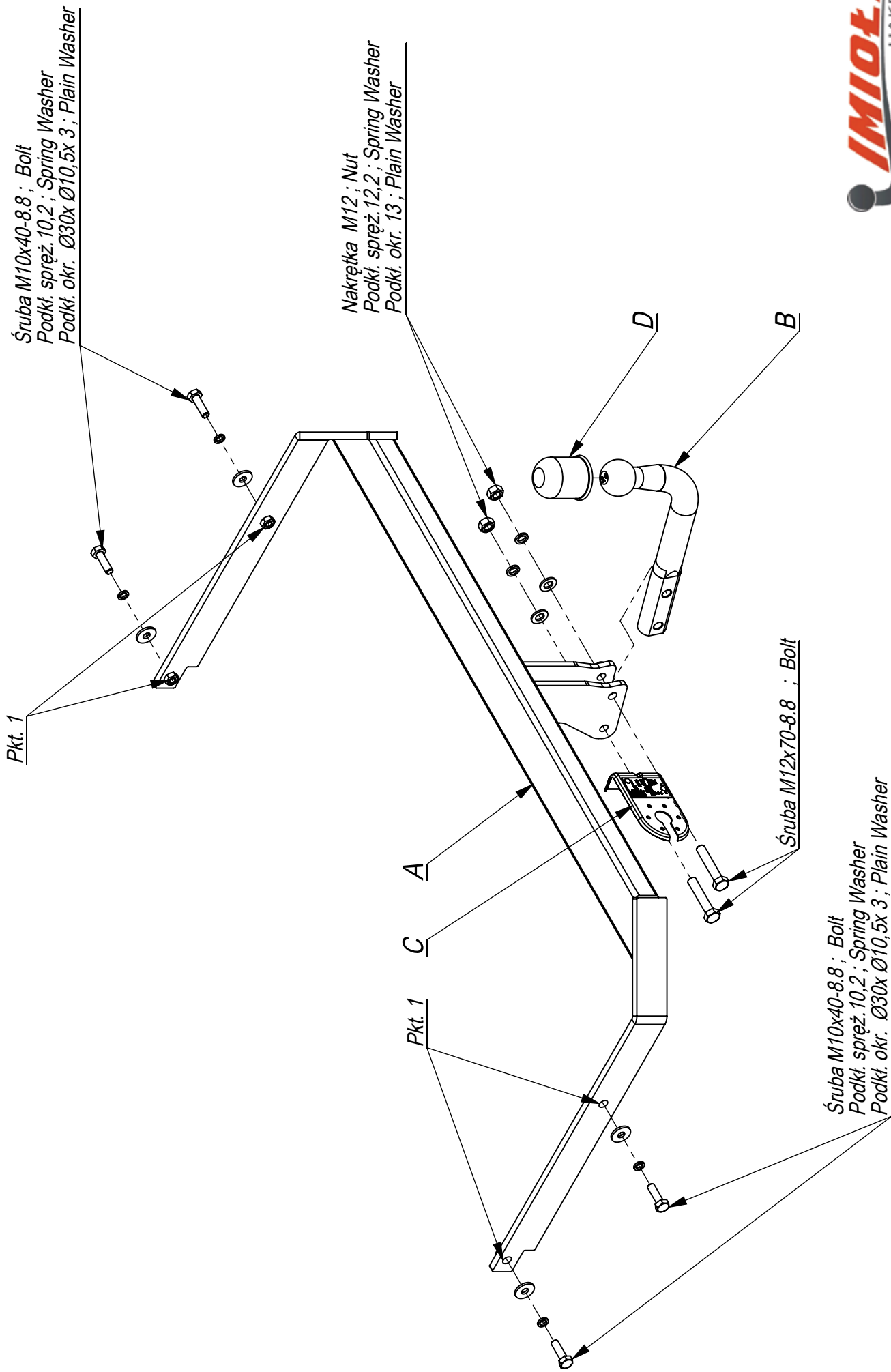

Nr katalogowy

X/010

Marka

Mazda 3 htb. sedan od 03 ->

- Zdemontować tylne lampy, zderzak oraz wypełnienie zderzak (nie będzie już wykorzystane).
- Wsunąć hak holowniczy w podłużnice i przykręcić poprzez technologiczne otwory w podłużnicach śrubami M10x35 8.8 (pkt 1).
- Zamontować zderzak oraz tylne lampy.
- Dokręcić kulę i blachę gniazda elektrycznego śrubami M12x70 8.8 (pkt 2).
- Podłączyć instalację elektryczną.
- Dokręcić wszystkie śruby z momentem wg tabeli.

- Disassemble the rear lights, bumper and filling of the bumper (it will not be used any more).
- Insert the tow bar in the metal clamps and screw through the technological holes in the metal clamps with bolts M10x35 8.8 (point 1).
- Assemble the bumper and rear lights.
- Fix the ball and electric plate with bolts M12x70 8.8 (point 2).
- Connect the electric wires.
- Tighten all the bolts according to the torque setting- see the table.

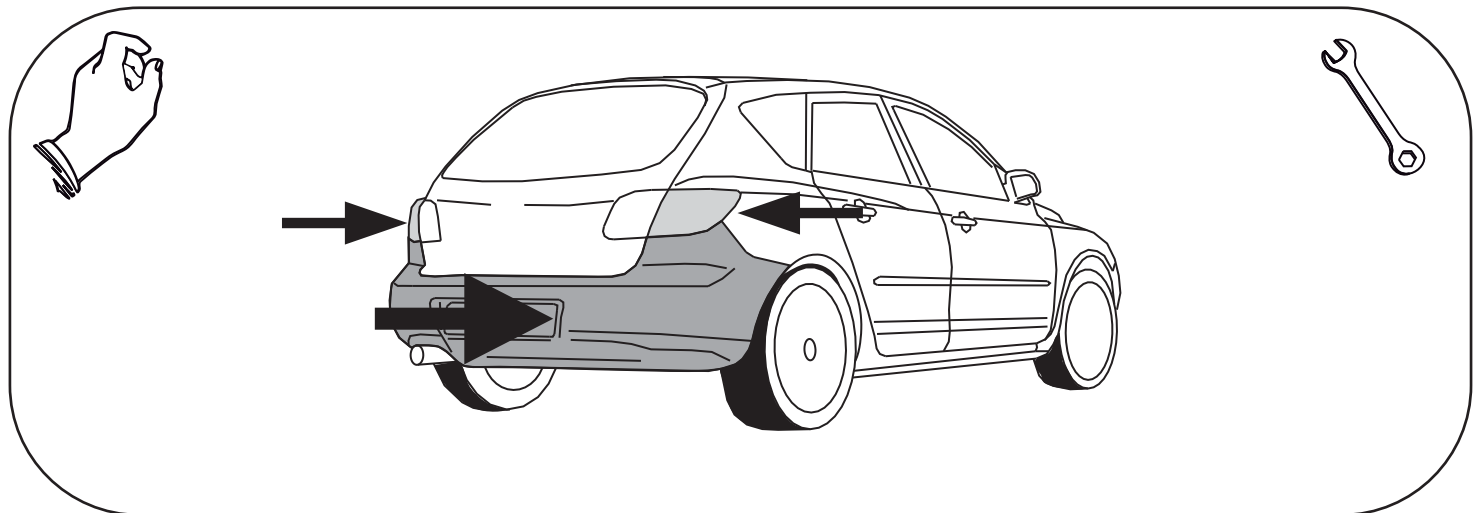
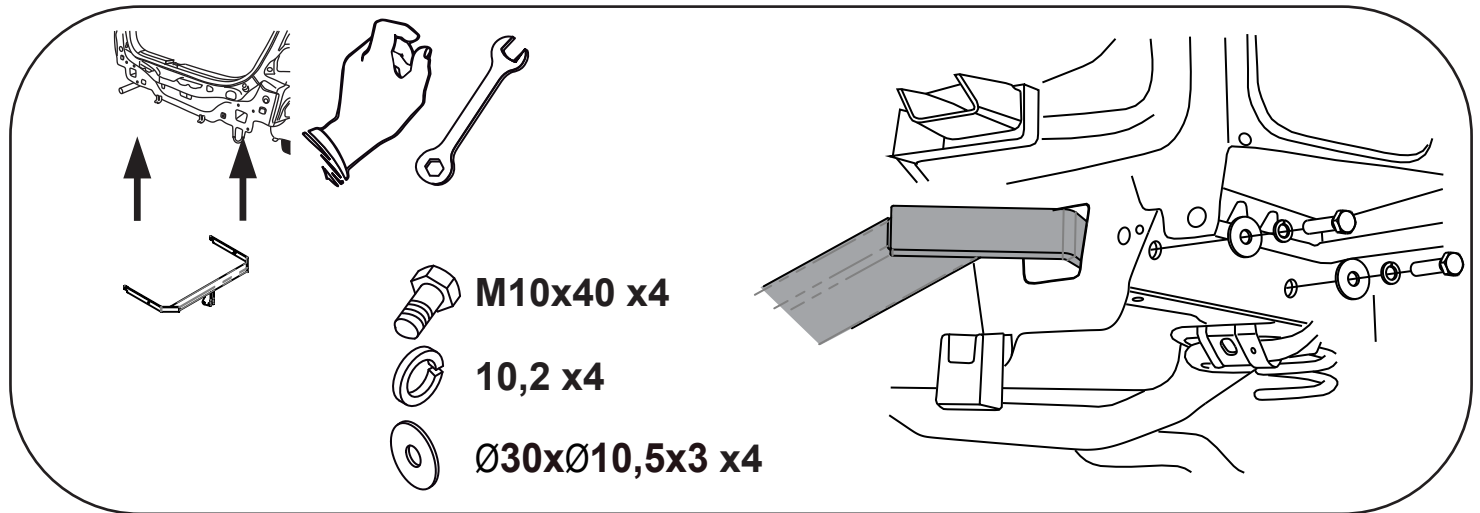
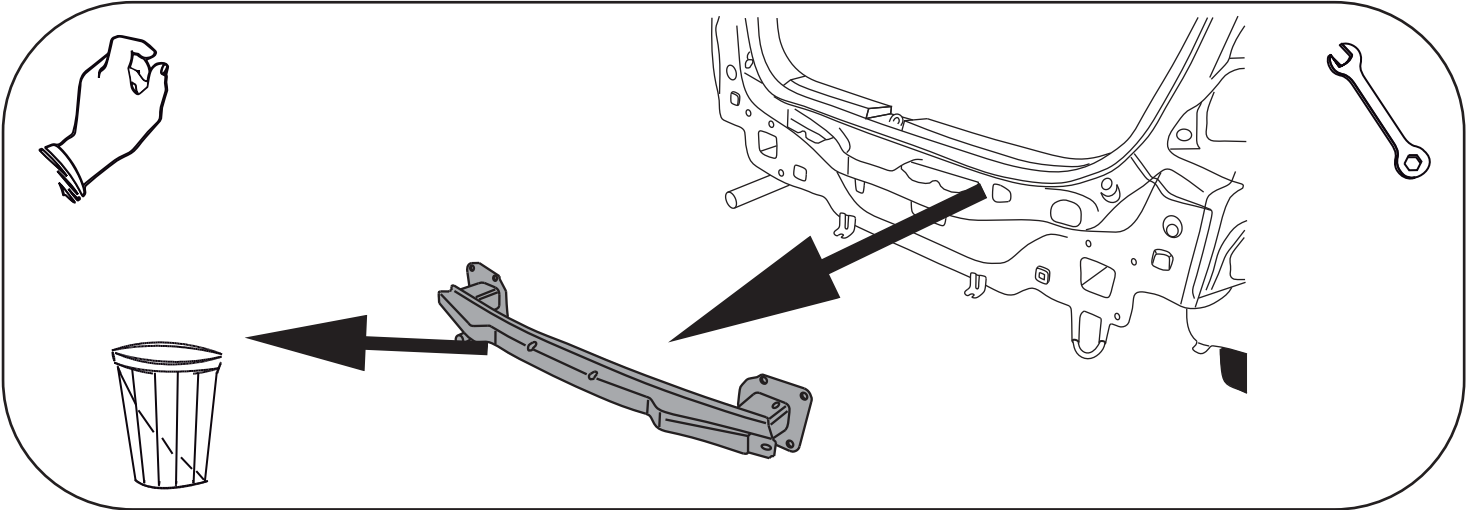
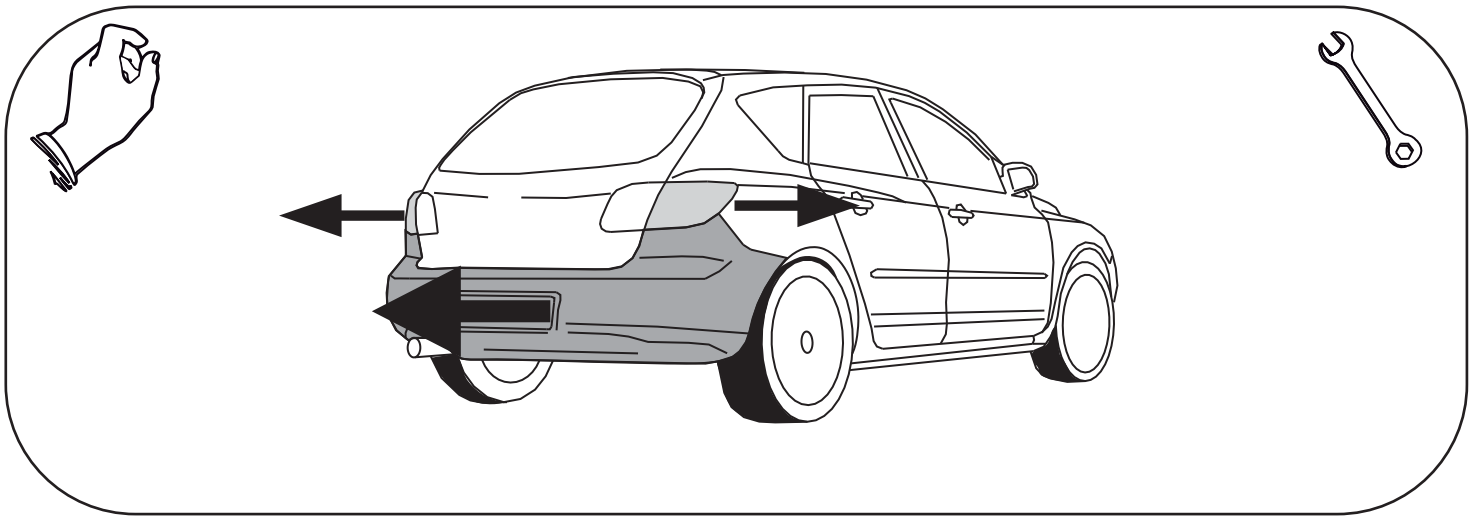

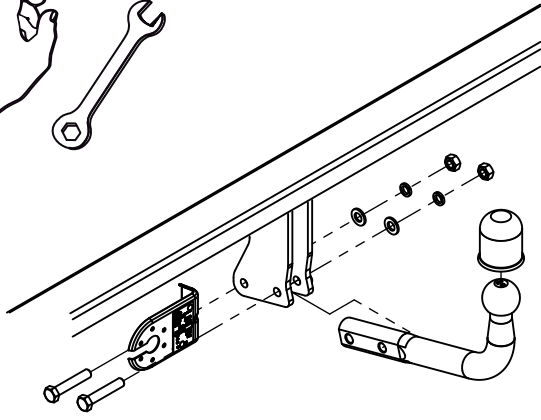
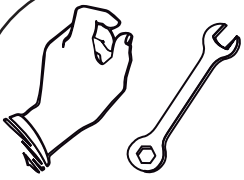

**M12x70 x2**



**12,2 x2**



**13 x2**

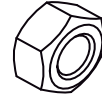

**M12 x2**