

ISTRUZIONI DI MONTAGGIO
FITTING INSTRUCTIONS
INSTRUCTIONS DE MONTAGE
MONTAGEANLEITUNG
INSTRUCCIONES DE MONTAJE
ИНСТРУКЦИЯ ПО УСТАНОВКЕ



DISPOSITIVO DI TRAINO TIPO TOWING DISPOSAL TYPE TYPE DU DISPOSITIF DE REMORQUAGE ANHÄNGERVORRICHTUNG TYP DISPOSITIVO DE CAREO TIPO ТЯГОВО-ЦЕПНОЕ УСТРОЙСТВО	39025
PER AUTOVEICOLI FOR CARS POUR VÉHICULES AUTOMOBILES FÜR KRAFTFAHRZEUGE PARA AUTOVEHICULO ДЛЯ АВТОМОБИЛЕЙ	TOYOTA AVENSIS BL. '03 2003 => (T25)
CLASSE E TIPO DI ATTACCO CLASS AND HITCH TYPE CLASSE ET TYPE DE CROCHET KLASSE UND BEFESTIGUNGSART CLASES DE ACOPLAMIENTO КЛАСС И ТИП СОЕДИНЕНИЯ	F
OMOLOGAZIONE HOMOLOGATION HOMOLOGATION ZULASSUNG APROBACION ОМОЛОГАЦИЯ	e3 00 – 7267 (DIR. 94/20/CE)
CARICO VERTICALE MAX S VALUE MASSE VERTICALE MAXIMUM ZUL. STÜTZLAST CARGA MAX. VERTICAL МАКСИМАЛЬНАЯ ВЕРТИКАЛЬНАЯ НАГРУЗКА	S = kg 80
VALORE D D VALUE VALEUR D D WERT VALOR D ЗНАЧЕНИЕ	$D = \frac{\begin{matrix} \text{Max } \downarrow \text{ Kg} \\ \text{---} \times \text{---} \\ \text{Max } \downarrow \text{ Kg} \end{matrix}}{\begin{matrix} \text{Max } \downarrow \text{ Kg} \\ \text{---} + \text{---} \\ \text{Max } \downarrow \text{ Kg} \end{matrix}} \times 0,00981 \leq \text{kN } 8,7$
COPPIA DI SERRAGGIO PER VITI (8.8): TORQUE SETTINGS FOR NUTS AND BOLTS (8.8): COUPLE DE SERRAGE POUR VIS (8.8): SCHRAUBENZUGSMOMENT (8.8): MOM. DE PRESION PARA TORNILLOS Y TUERCAS (8.8): СПИСОК ДЕТАЛЕЙ (8.8):	M6 = Nm 10 M8 = Nm 25 M10 = Nm 55 M12 = Nm 85 M14 = Nm 135 M16 = Nm 200

NOTES D'INFORMATION

- ◆ Avant l'installation assurez-vous que le crochet d'attelage soit compatible avec véhicule sur lequel il doit être installé; vérifiez que le type d'attelage et l'extension ou le type de véhicule, indiqués dans la carte grise, soit présent dans le document du crochet d'attelage. Dans le cas contraire, vous pouvez nous contacter à l'adresse mail suivante: umbrarimorchi@umbrarimorchi.it pour plus d'informations ou pour demander des documents mis à jour.
- ◆ Le crochet d'attelage est un élément de sécurité et doit pour cela être installé uniquement par du personnel qualifié.
- ◆ Les éléments endommagés ou usagés doivent être remplacés seulement par du personnel qualifié.
- ◆ Il est interdit d'effectuer toutes modifications significatives ou réparations sur la structure de l'attelage.

UTILISATION ET ENTRETIEN

- ◆ La boule de l'attelage doit être propre et lubrifiée. Pour plus de sécurité, contrôler périodiquement le diamètre de la boule: si ce dernier est de 49 mm en plusieurs points, le crochet d'attelage ne pourra plus être utilisé jusqu'au remplacement de la boule.
- ◆ Après 1000 km de tractage toute la boulonnerie de l'attelage doit être contrôlée en vérifiant le couple de serrage selon le tableau ci-joint.

	39025	23/06/14 v. 1.0	P. 2 / 13
			

39025

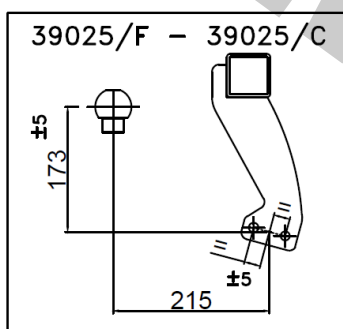
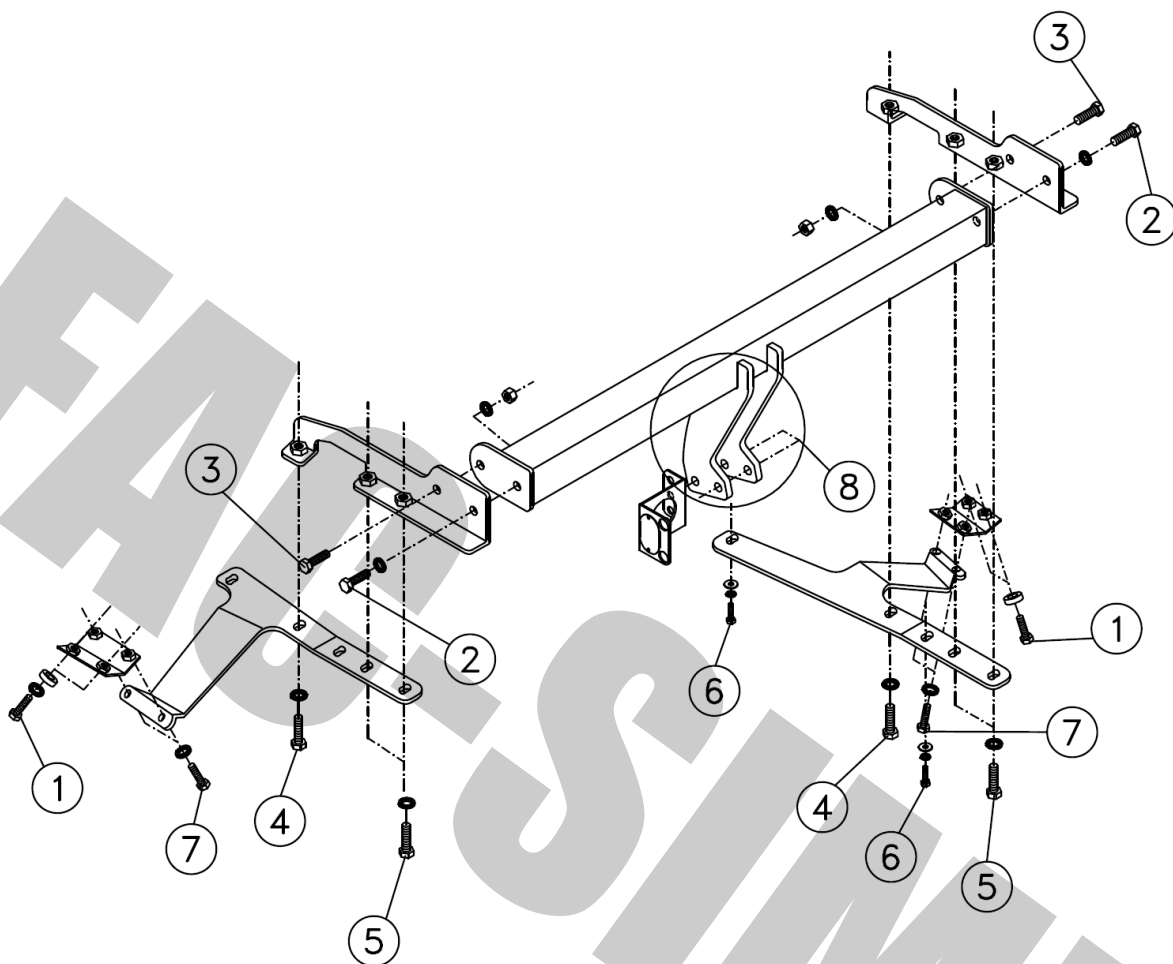

















39025



23/06/14 v. 1.0

P. 3 / 13



①	4x	 M8x25	 CONTACT 8x18x1,4	 \varnothing 25x5 Lg. 9mm
②	2x	 M10x30	 CONTACT 10x22x1,5	
③	2x	 M10x30	 CONTACT 10x22x1,5	 M10
④	2x	 M10x35	 CONTACT 10x22x1,5	
⑤	4x	 M10x50	 CONTACT 10x22x1,5	
⑥	2x	 M6x20	 CONTACT 6x14x1,2	 6x18x1,5
⑦	4x	 M8x25	 CONTACT 8x18x1,4	



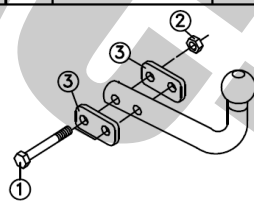

08

39025/F			
①	2x	M12x85 (8.8)	
②	2x	M12 (8.8)	
③	2x	SPESSORI SPACERS	



U.R. SF12/C
e3 00-7672
E57 55R-01 0003

(F21A)

39025/C			
①	2x	M12x25 (8.8)	
②	2x	12.2x27x2.5	
③	1x	M12x85 (8.8)	
④	1x	M12 (8.8)	

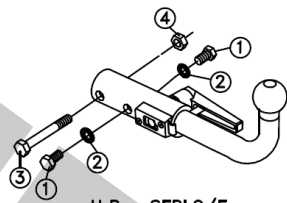

U.R. SFBLC/E
e3 00-7137

(21 AY)



39025

23/06/14 v. 1.0

P. 4 / 13



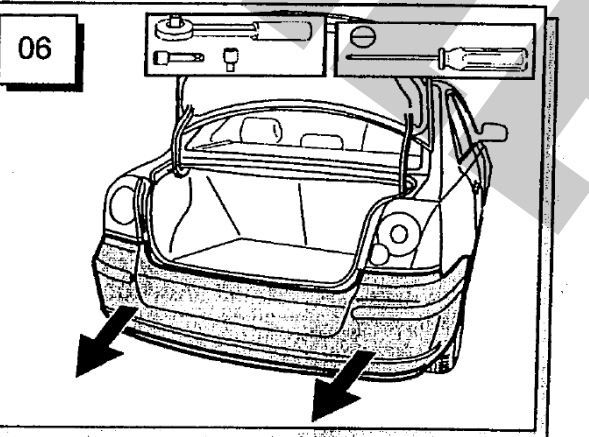
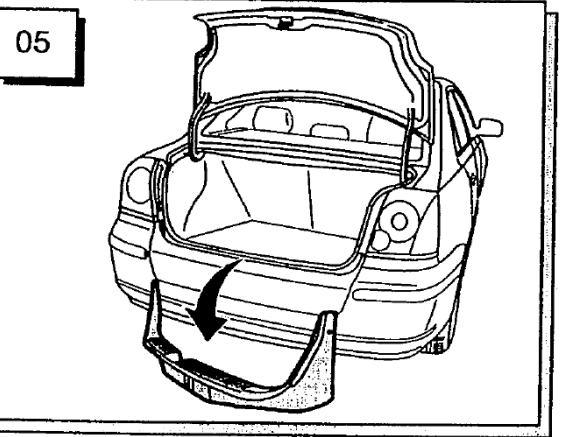
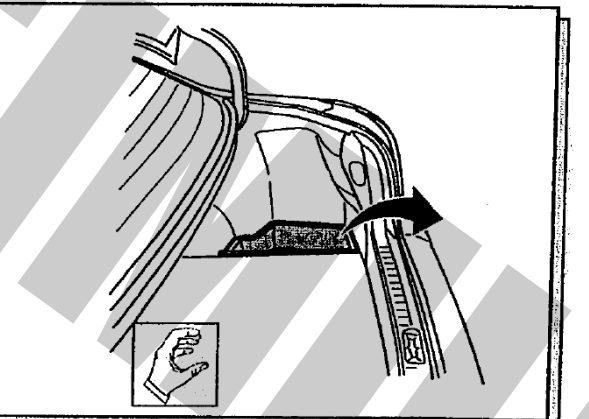
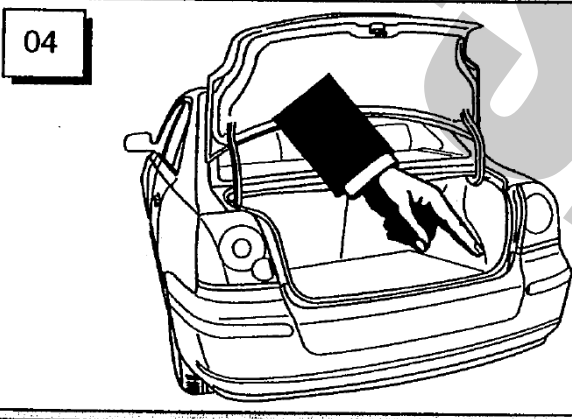
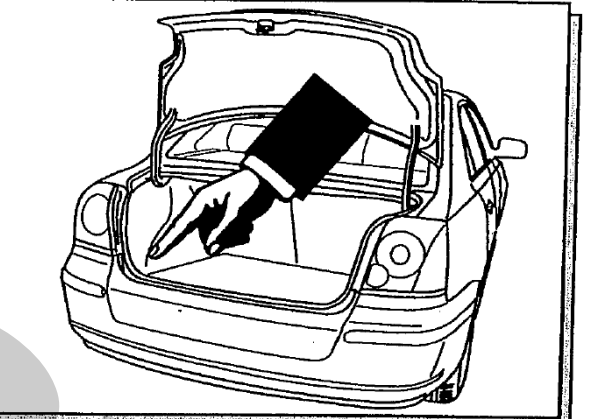
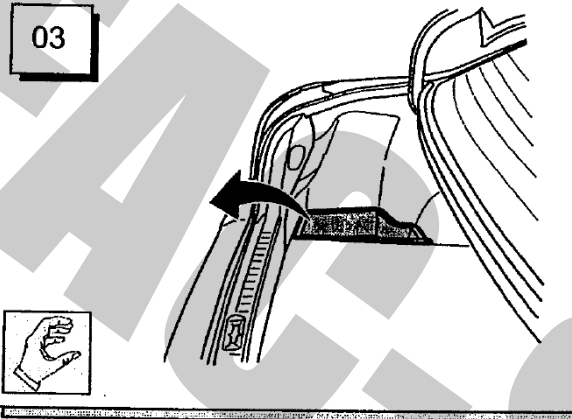
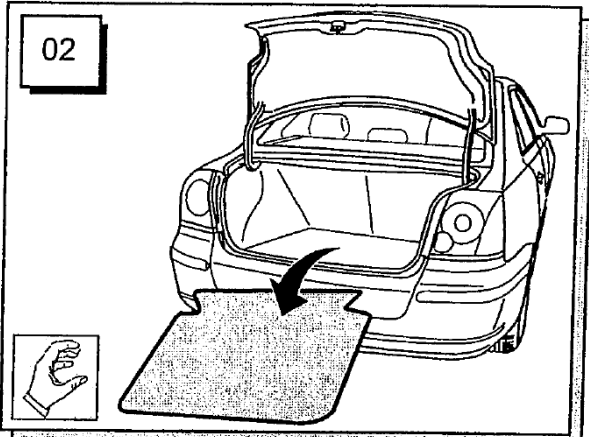
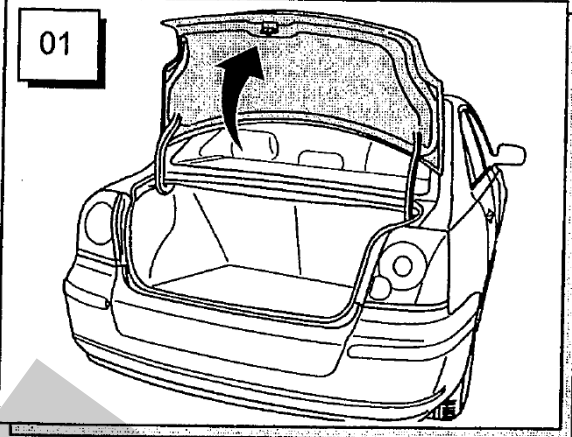

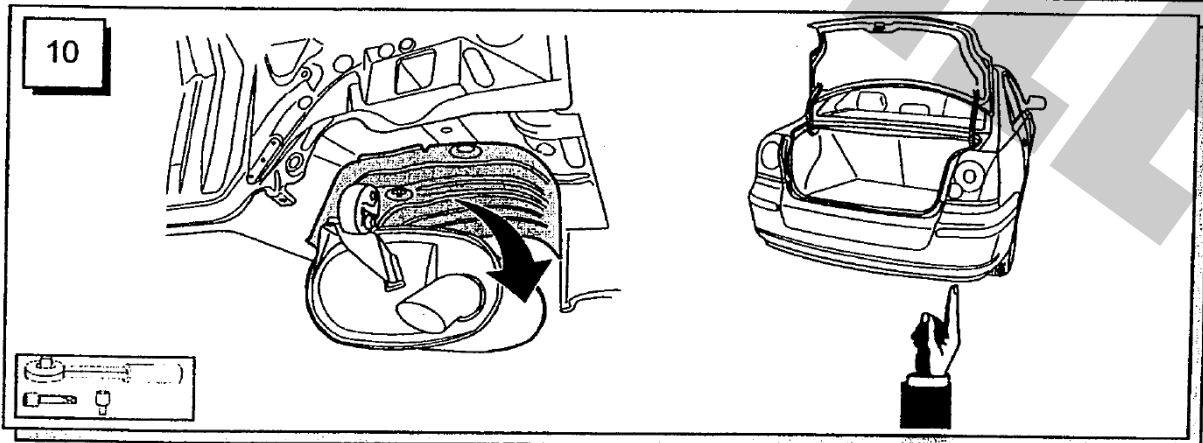
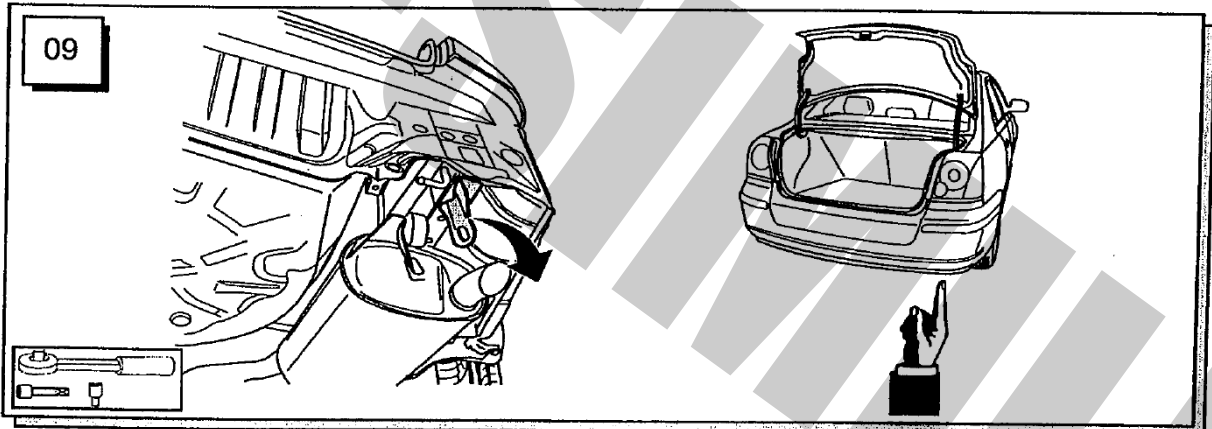
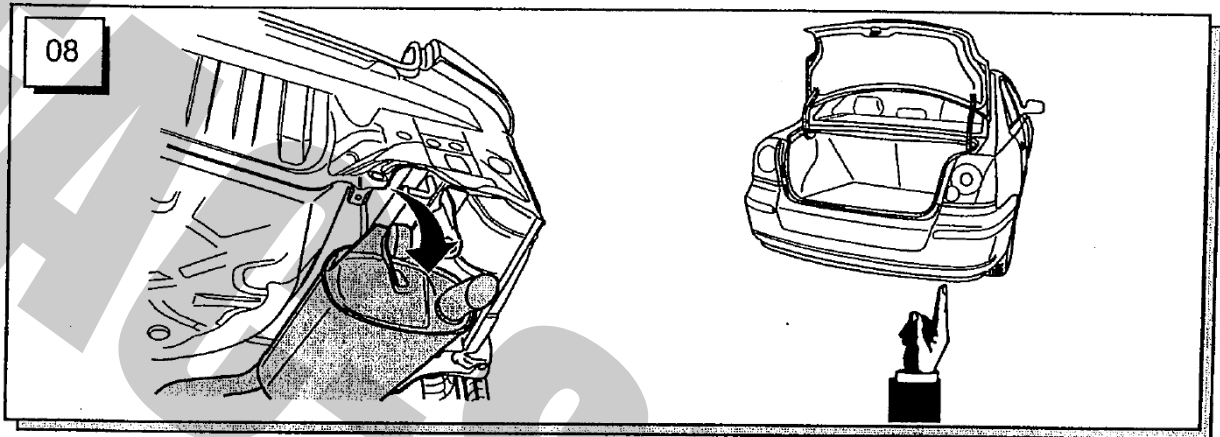
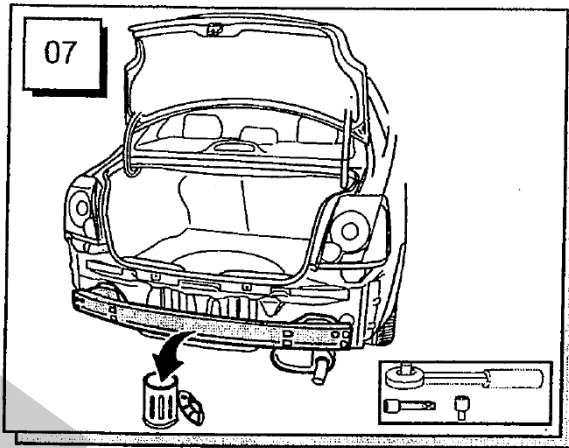

11

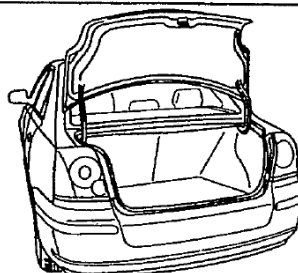
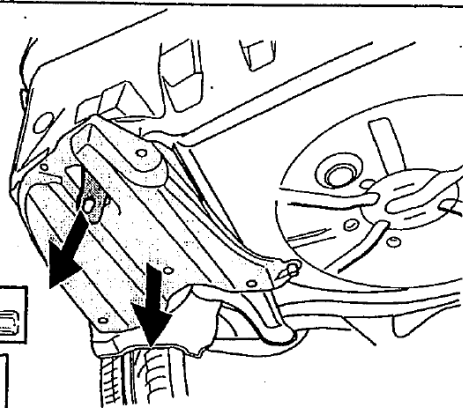
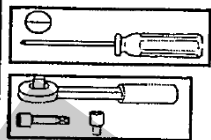

12

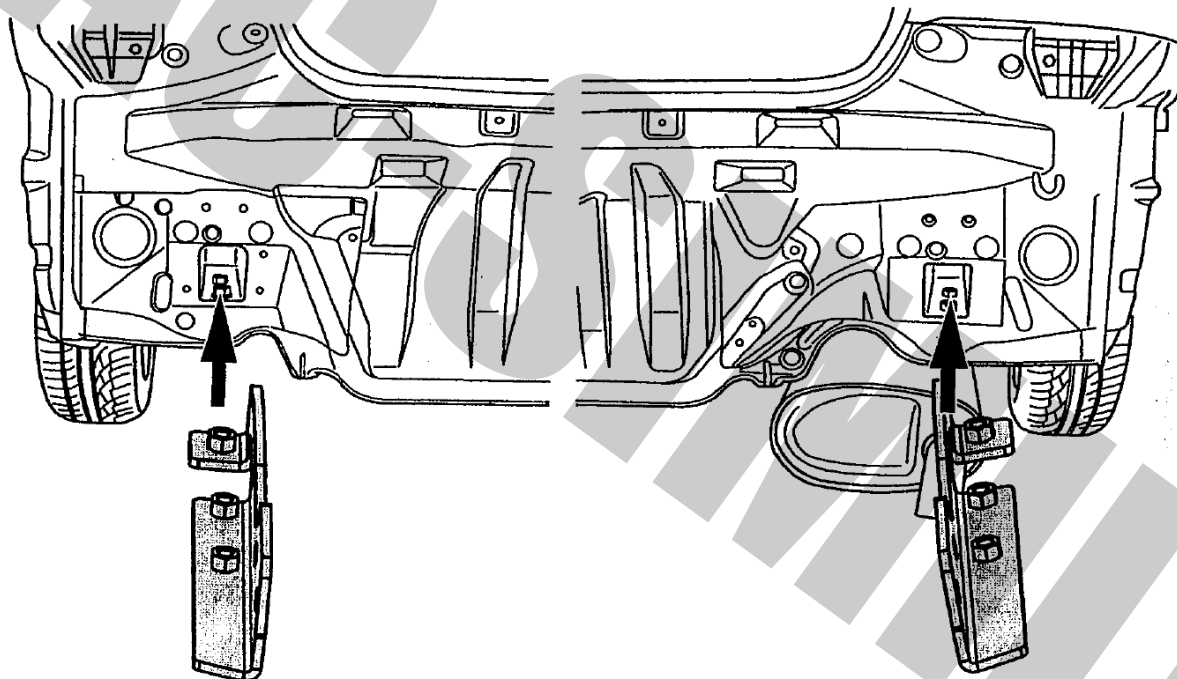

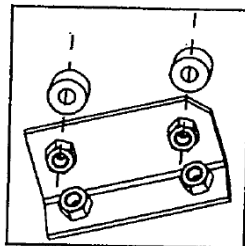

Ø25x5x9(2x)

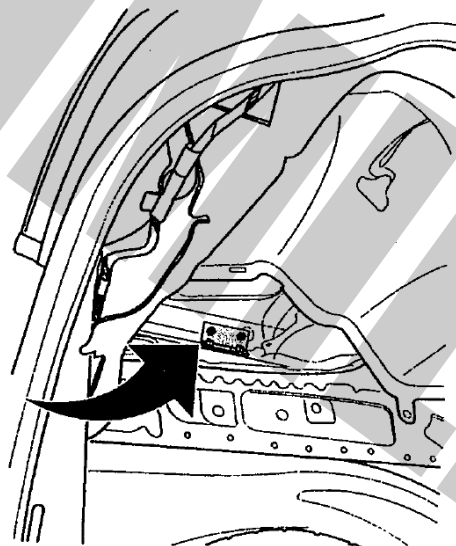
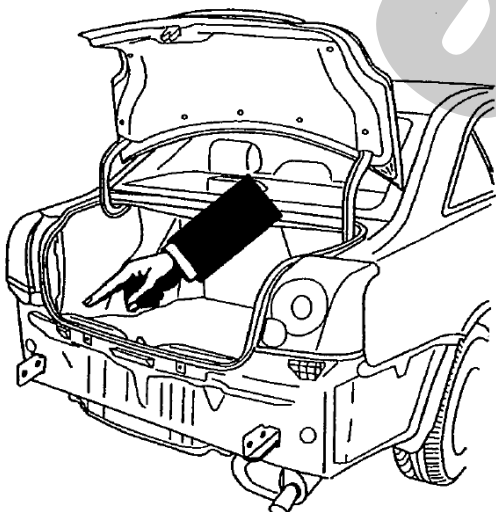
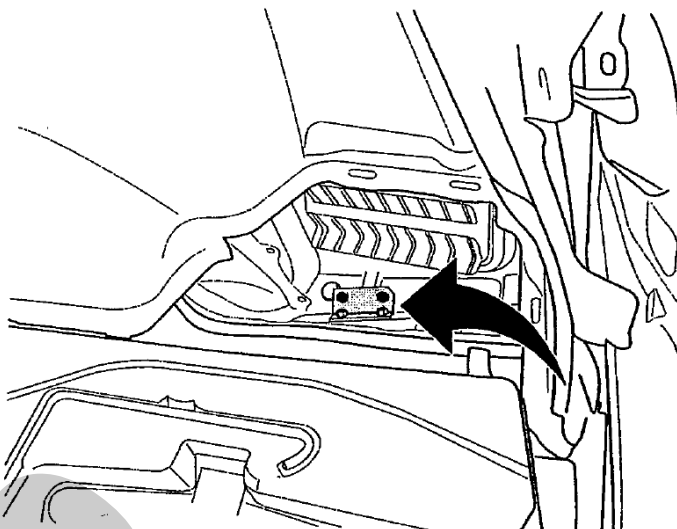
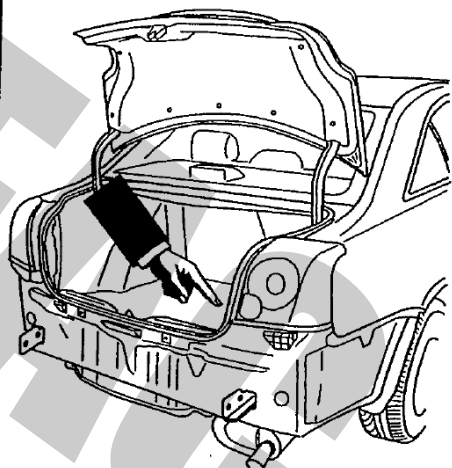

Ø25x5x9(2x)

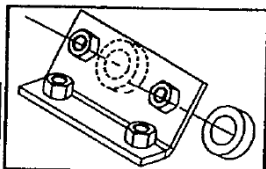

14

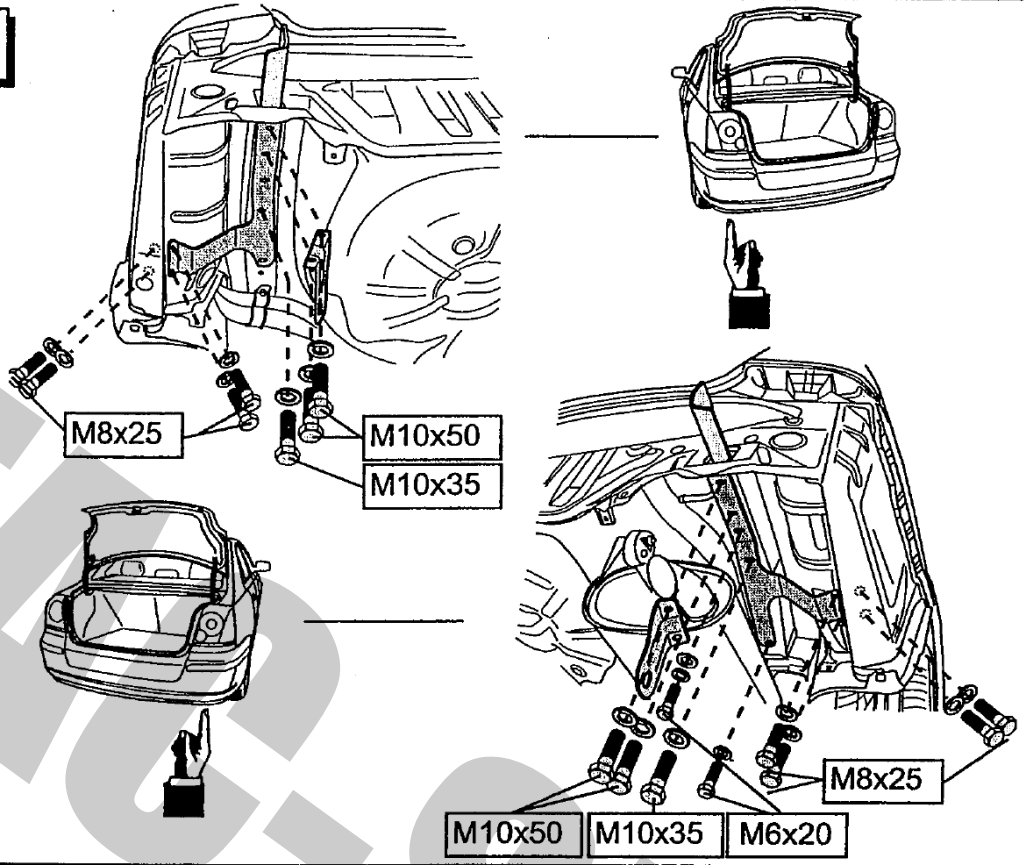

15

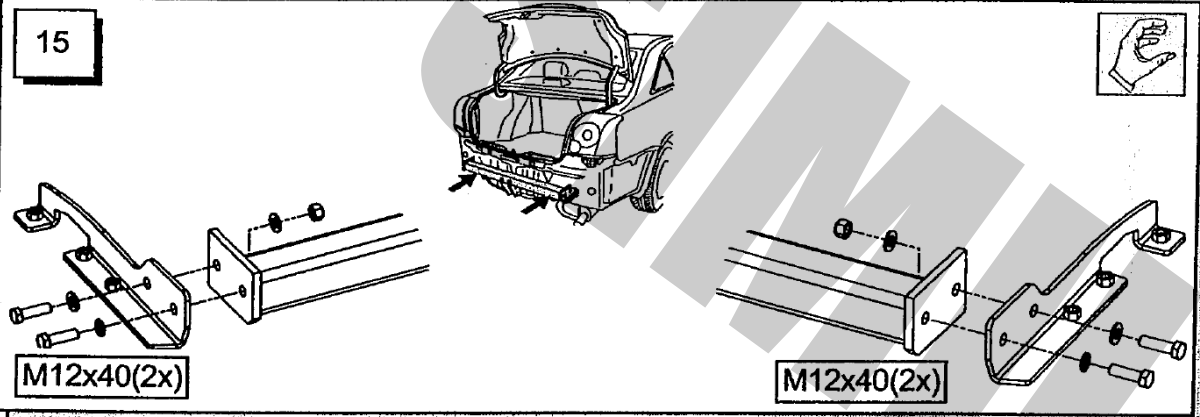

16

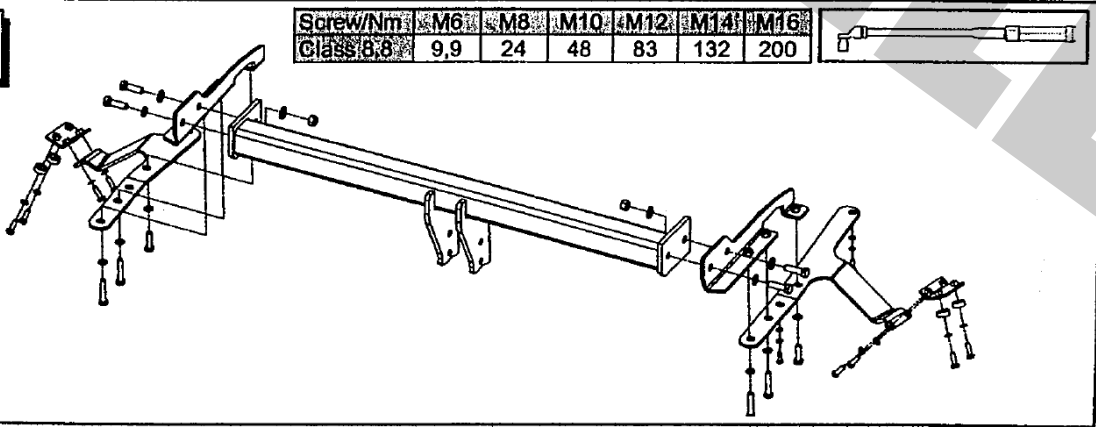

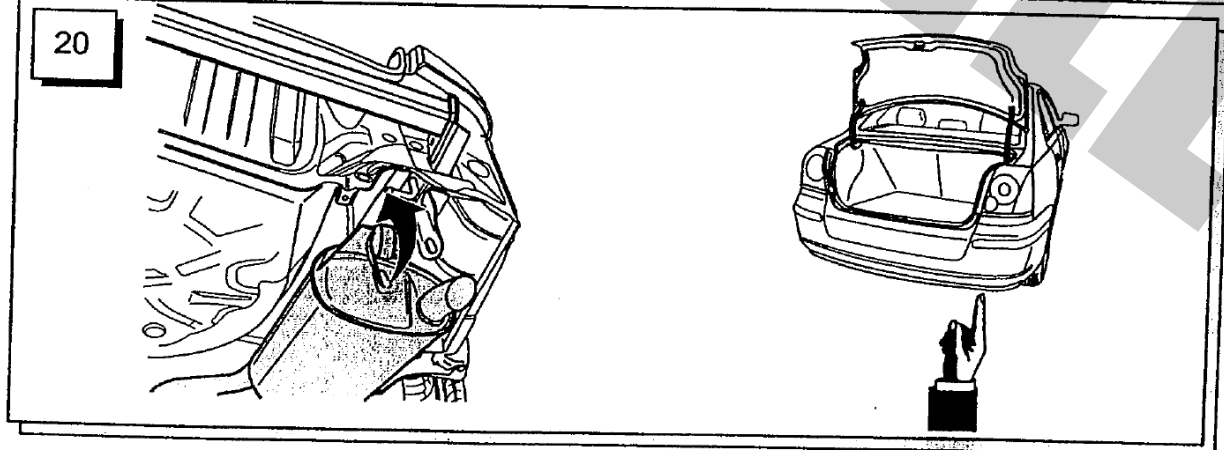
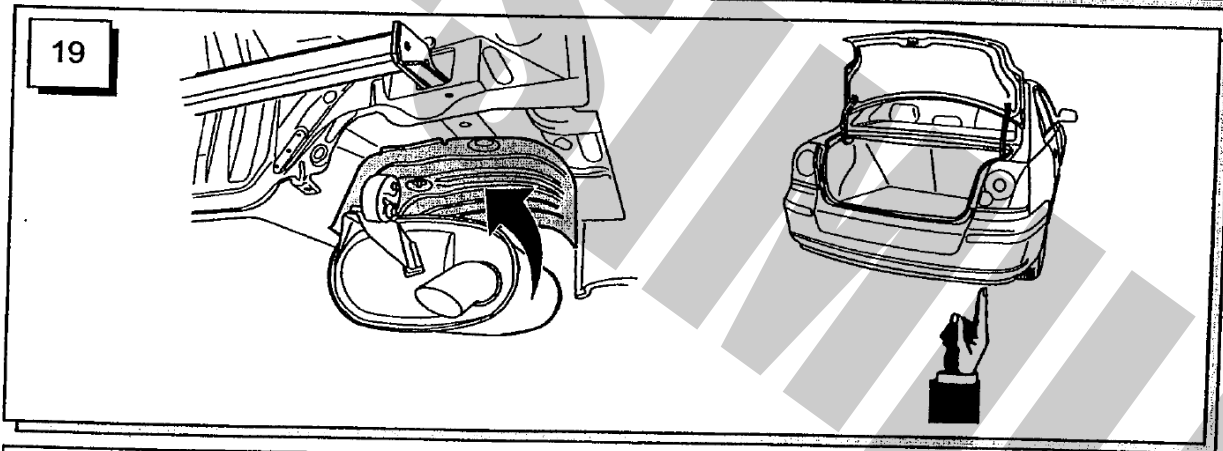
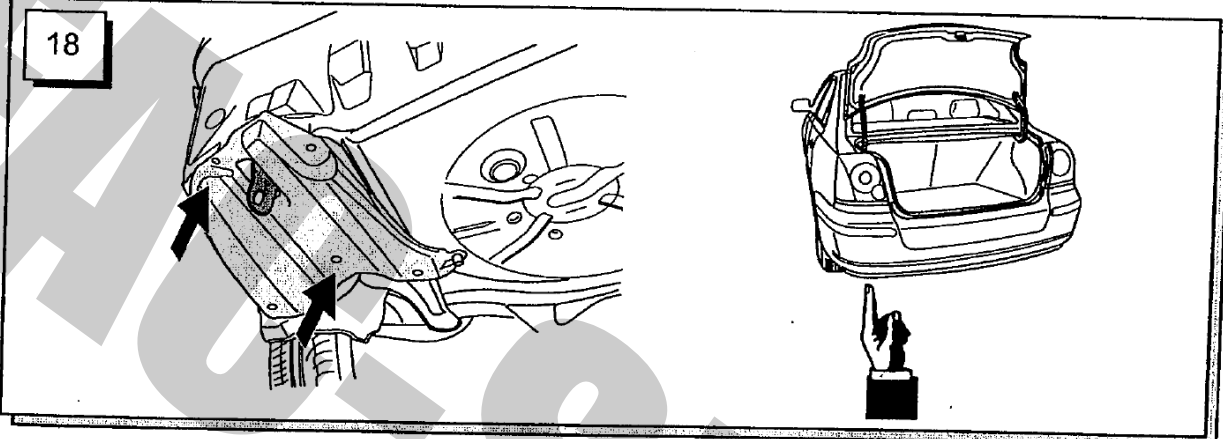
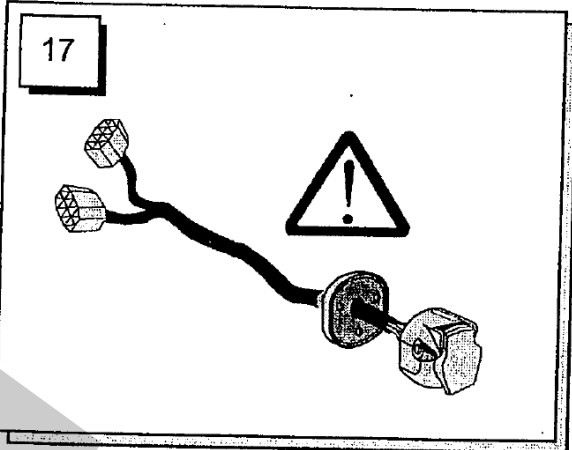

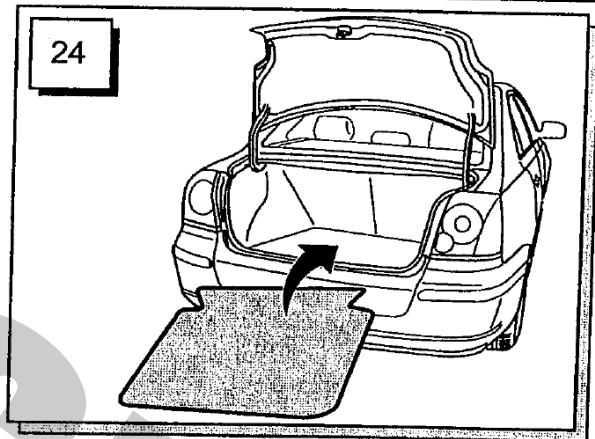
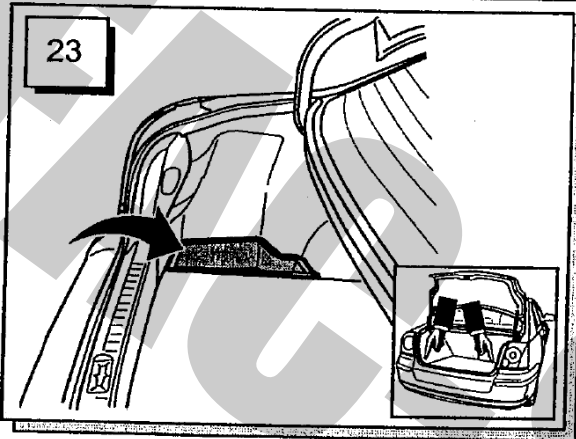
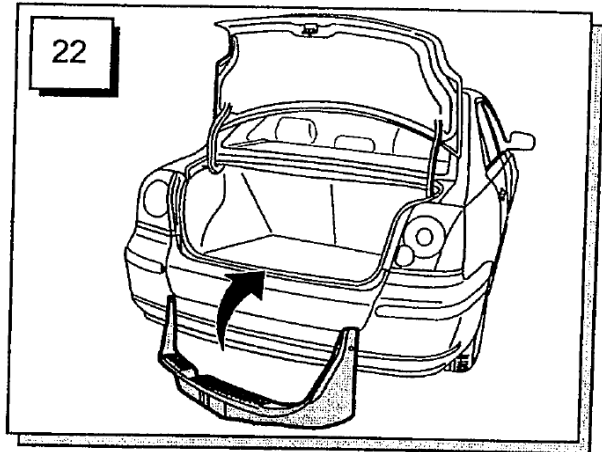
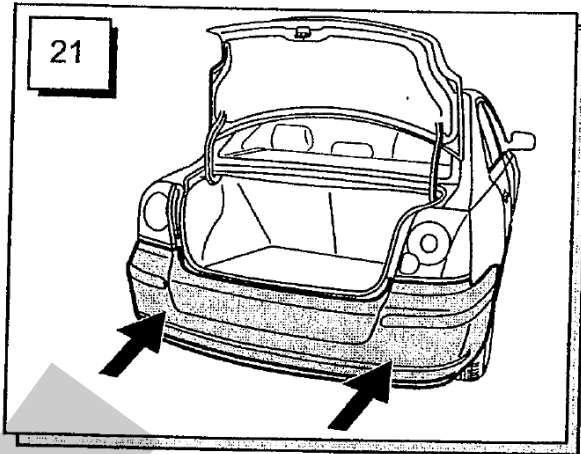

MECCANISMO MOD. C 2007



tel +39 075 5280260
 fax +39 075 5287033
www.umbra-rimorchi.it
umbra.rimorchi@umbra-rimorchi.it

NL - Montage	S - Montering	I - Montaggio
GB - Mounting	DK - Tilkobling	
D - Montage	FIN - Asennus	
F - Montage	E - Montaje	

NL - Demontage	S - Demontering	I - Smontaggio
GB - Disounting	DK - Frakobling	
D - Demontage	FIN - Irrota	
F - Démontage	E - Desmontaje	

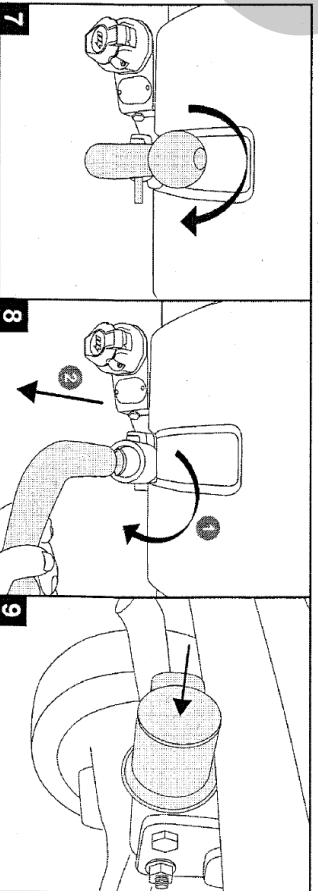
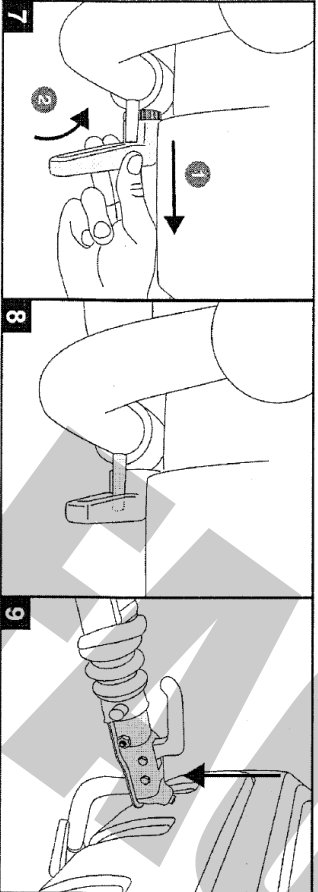
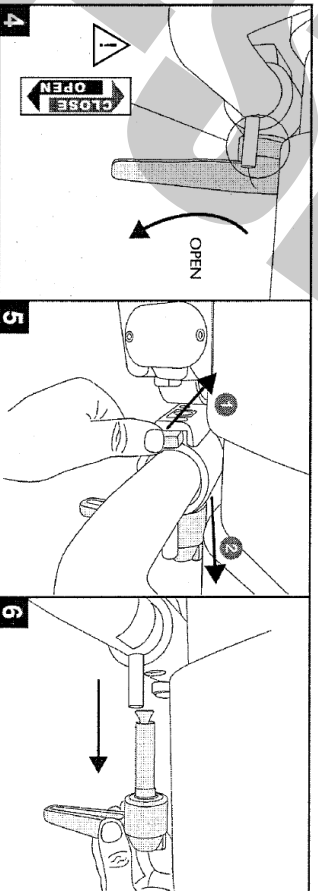
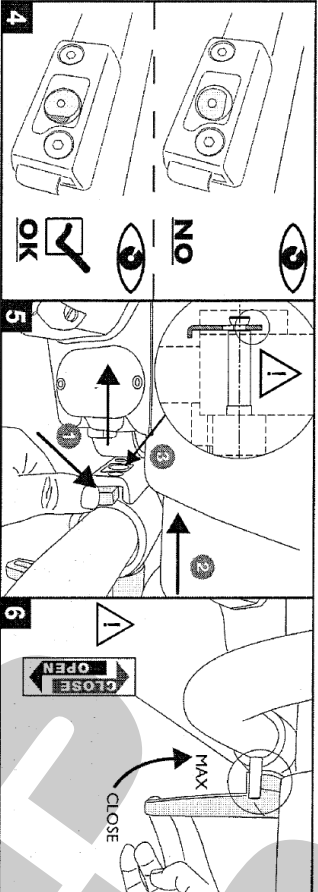
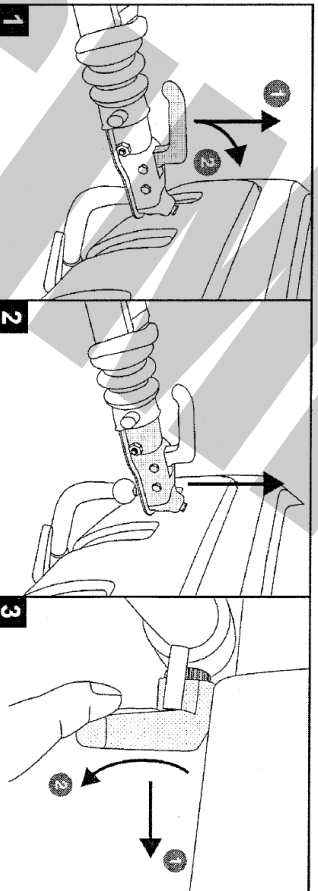
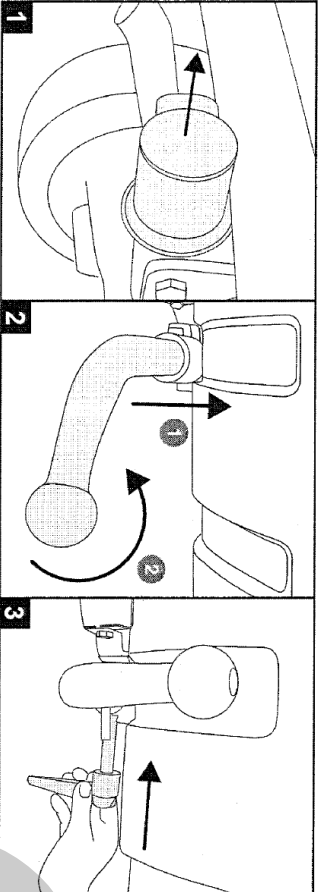

39025

23/06/14 v. 1.0

P. 12 / 13



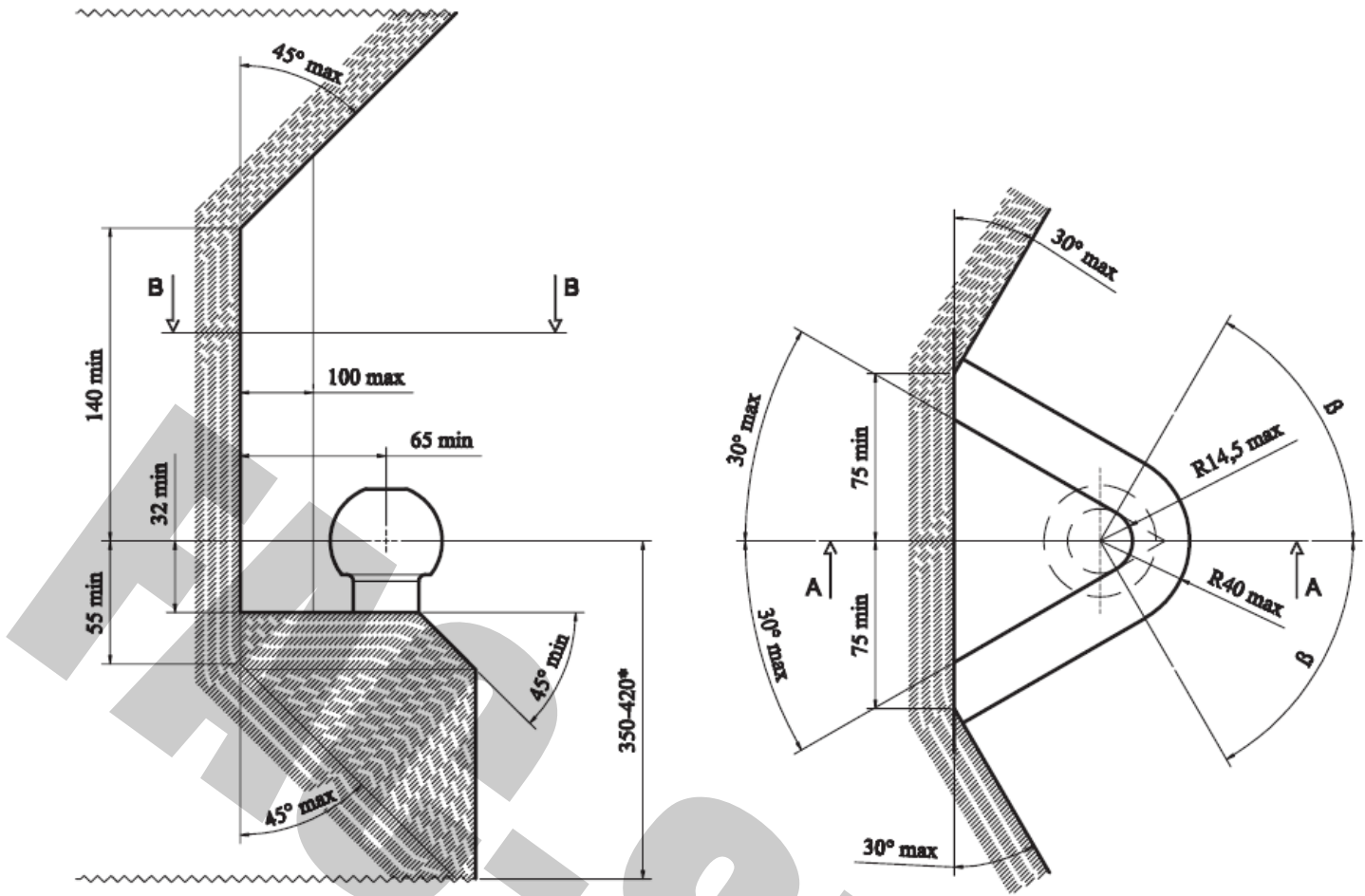

I	D
<p>Deve essere garantito lo spazio libero secondo l'allegato VII, figura 30 della direttiva 94/20/CE.</p> <p>*per il peso complessivo ammesso del veicolo</p>	<p>Der Freiraum nach Anhang VII, Abbildung 30 der Richtlinie 94/20/EG ist zu gewährleisten.</p> <p>* bei zulässigem Gesamtgewicht des Fahrzeuges</p>
GB	RU
<p>The clearance specified in appendix VII, diagram 30 of guideline 94/20/EC must be guaranteed.</p> <p>*at gross vehicle weight rating</p>	<p>Должно быть гарантировано свободное пространство в соответствии с Приложением VII, рисунок 30 Директива 94/20/ЕС для массы транспортного средства</p>
F	UA
<p>L'espace libre doit être garanti conformément à l'annexe VII, illustration 30 de la directive 94/20/CE.</p> <p>*pour poids total en charge autorisé du véhicule</p>	<p>Повинен бути гарантоване вільний простір відповідно до Додатку VII, малюнок 30 Директива 94/20/ЕС для маси транспортного засобу</p>